

A red paper airplane is shown in flight, angled upwards and to the right, against a white background.

Repair Handbook

A young child with dark hair in braids is wearing a black ski helmet with yellow goggles. The child is wearing a pink, ruffled, long-sleeved top and is pointing directly at the camera with their right hand. A black ski pole is visible behind their shoulder.

Infinite Possibilities

How to report repairs

During normal office hours

Tel: 0800 111 4013

Email: service.centre@longhurst-group.org.uk

Out of hours emergencies (emergency repairs only)

Tel: 0800 111 4013

On our website (non-urgent repairs only)

www.longhurst-homes.org.uk

Important equipment

Make a note of where your important equipment is in your property. Fill this table in now for your future reference.

| IMPORTANT EQUIPMENT | WHERE IS IT? |
|---|--------------|
| Mains water stop valve inside your home | |
| Electric fuse box and trip switch | |
| Gas supply tap | |
| Central heating boiler | |
| Cold water storage tank | |
| Hot water tank | |

For advice on looking after your home see Helpful Tips on page 72

Contents

Introduction

| | |
|---------------------------------|----|
| Repair priorities | 4 |
| Who is responsible for repairs? | 6 |
| Improvements and alterations | 8 |
| Quality control | 10 |
| Code of conduct | 10 |
| Complaints | 11 |
| Emergencies | 15 |

Bathrooms and WC

| | |
|----------------|----|
| Baths / basins | 16 |
| Showers | 20 |
| WC | 22 |

Water system

| | |
|-----------|----|
| Water | 26 |
| Hot water | 28 |

Communal facilities

| | |
|---------------------|----|
| Communal facilities | 30 |
|---------------------|----|

External doors and windows

| | |
|----------------|----|
| External doors | 32 |
| Windows | 38 |

Gardens, fences and garages

| | |
|----------------|----|
| Fences | 42 |
| Garages | 44 |
| Gardens | 44 |
| Paving & steps | 46 |
| Gates | 48 |
| Garden walls | 48 |

Heating, gas and electrical

| | |
|-----------------|----|
| Electrical | 50 |
| Heating systems | 54 |

Internal doors

| | |
|----------------|----|
| Internal doors | 58 |
|----------------|----|

Kitchens

| | |
|---------------|----|
| Kitchen units | 60 |
|---------------|----|

Roofs, chimneys and rainwater

| | |
|-----------------------|----|
| Chimneys and roofs | 64 |
| Drains | 66 |
| Gutters and downpipes | 68 |

Stairs

| | |
|--------|----|
| Stairs | 70 |
|--------|----|

Helpful tips

| | |
|-------------------------------------|-----------|
| Looking after your home | 72 |
| Condensation | 73 |
| Leaking, burst or frozen pipes | 73 |
| Bleeding a radiator | 75 |
| Loss of electric light or power | 76 |
| Controlling your central heating | 78 |
| Clearing a blocked waste pipe | 79 |
| Clearing a blocked WC | 79 |
| Overflows | 80 |
| Stopcocks, gate valves etc | 81 |
| Index | 82 |

Introduction

The Repairs Handbook for tenants has been produced on behalf of Longhurst Homes to provide general advice to you on dealing with repairs.

When reporting a repair, call 0800 111 4013, e-mail us at service.centre@longhurst-group.org.uk or fill in the online form at www.longhurst-homes.org.uk and give us as much of the following information as you can:

- Type of repair (use this book to identify the correct name for the part that needs repairing).
- Where in your home the repair is required i.e. kitchen, outside etc.
- If relevant – whether the appliance is electric or gas.
- Access Details – Whether there are any times or days when you will not be at home.
- Contact Details – Confirm your telephone number.

When you report a repair you will be sent confirmation of your repair request. This will include details of the work to be carried out, the name of the contractor and when the repair should be completed by.

REPAIR PRIORITIES

Emergency repairs

Emergency repairs will be carried out within 24 hours.

An emergency is a repair which could not have been foreseen and which could cause danger to health, residents' safety, or serious damage and destruction to property. Emergency call out contractors will normally make safe and if further work is required



then a follow up order will be issued. The list includes:

- Severe roof leaks, which cannot be controlled causing flooding to property.
- Burst pipes.
- Blocked drains.
- Broken toilet, where only one exists in property.
- Total loss of electrical power or light.
- Loss or smell of gas – ring National Grid on 0800 111 999.
- Total loss of heating between 1st October and 30 April.
- Loss of immersion heater if this is the only source of hot water.
- Damage caused by fire, making safe only.
- Fire and smoke alarms which consistently sound and cannot be reset.
- Lift breakdown and persons trapped inside.
- Securing doors and windows where security of property is at risk.
- Damaged manhole covers.

We recognise that elderly and vulnerable tenants will need special consideration in certain circumstances.

If a contractor is called out to an emergency repair and it is not justified then you are liable to be charged for all costs concerned.

Urgent repairs

Urgent repairs will be completed within 7 calendar days.

These are repairs that could directly affect the comfort or convenience of the resident but do not place them in any immediate danger. The list includes:

- Partial loss of electrical power or lights.
- Partial loss of water.
- No heating between 1st May and 30th September.
- Minor leaks from water pipes, tanks or cisterns.
- Rotten timber floor, or stair tread and handrail.
- Missing roof tiles and minor roof leak.

- Door entry phone not working.
- Extractor fans not working in kitchen or bathroom with no other source of ventilation.
- Fire and smoke alarms.
- Communal laundry equipment which is responsibility of Association and no alternative exists.
- Blocked or broken toilet if second one within property.
- Communal television aerials, cooker or fridge, which is responsibility of Association.

Non urgent repairs

All other repairs not listed under emergency or urgent repairs will be put into our proactive planned repair programme or an order will be issued on a 31 or 90 calendar day priority.

Planned maintenance

Where maintenance can be planned in advance we can arrange for it to be done on a group of homes at the same time, be more cost effective and be more proactive in maintaining your home. This will include work to

your home to ensure that it remains in good order, and provide safe accommodation for you and your family. Examples include external painting, repairs to gutters, doors and windows in preparation for painting, annual servicing of gas appliances, path and fencing repairs. We may need to carry out surveys before the work starts and you will be contacted to arrange access. You will also be informed in advance by the contractor or us when the work is due to start.

WHO IS RESPONSIBLE FOR REPAIRS?

As your landlord, we have a legal duty to carry out certain repairs when these are needed. As legislation changes, the responsibility for specific repairs may also change.

This means that there may be times when we have carried out certain repairs in the past, but because of changes in the law, a specific repair may become your responsibility, or vice versa.



We expect that as time passes, normal wear and tear will occur to your home. However, should your home need a repair because of either neglect or damage by you or your friends or family, we will expect you to carry out any necessary repairs. We may give you notice to make good, and in some cases we may carry out the repair on your behalf and then charge you for the cost. There may, however, be some occasions when we will carry out a repair for which we are not generally responsible. This will usually depend on your circumstances and these are known as discretionary repairs.

The sections below and on pages 12, 13 and 14 give advice on which repairs are our responsibility, and

which are yours. If you still have any queries about whose responsibility a specific repair is then ring us on 0800 111 4013.

Environment

We are all responsible for the environment so please do not put paint, oil or petrol into the drains, dump large items of furniture or leave any litter or broken glass around.

We will investigate all reports of illegally dumped rubbish and may take action against anyone found to be dumping rubbish.

Your responsibilities

You are responsible for keeping your home in a reasonable condition and for attempting to solve minor problems. Please refer to chart on pages 12, 13 and 14 for further details on specific repairs, together with the helpful tips on page 72.

We will insure the structure of your home but you are responsible for insuring your own contents.

You are expected to take reasonable precautions to prevent damage to the property by fire, frost, the bursting of water pipes or the blocking of drains and sinks.

We rely on you to report any faults promptly by ringing us on 0800 111 4013 and to provide access to our contractors to ensure that the repair can be undertaken within our agreed timescales.

Finally, remember that someone else will be moving into your home if you ever decide to leave. Please make sure that the property is clean, tidy, reasonably decorated and that all your unwanted belongings have been cleared, including any in the roof space. You will also need to complete any repairs that are your responsibility.

Our obligations

We are obliged to keep the structure and exterior of your home in good repair together with the building in which it is situated.

We also undertake to keep in

good repair and proper working order installations for the supply of water, gas and electricity, sanitation and room and water heating.

In the case of flats and maisonettes, we will take reasonable care to keep common entrances, corridors, communal lounges, stairways, lifts, rubbish chutes and any other common parts in reasonable repair.

Please refer to the chart on pages 12, 13 and 14 for further details on specific repairs.

Vandalism or graffiti

We need your help to combat vandalism. Do not assume that someone else will report vandalism; tell us quickly if you know of any. We will prosecute vandals when there is a witness, to discourage others, and save rent money being used to repair vandalised areas.

IMPROVEMENTS AND ALTERATIONS

Before you make any alterations to your home you must write to us



to obtain permission. We have to ensure that your home is not damaged or made unsafe. It is your responsibility to get any planning permission you need, and comply with building regulations. An alteration is anything which is an addition or change to the property or its gas, electrical, water or drainage supply.

Examples of the most common alterations are given below but this list is not meant to be complete and you should ask us for more details before you do any work:

- Moving/removing fitted units or doors.
- Plumbing in washing machines or other appliances.
- Building patios.
- Knocking down walls.

- Double glazing.
- Extensions, garages and conservatories.
- Satellite dishes.
- Erecting sheds.
- Enclosing porches.
- Additional fencing .
- Electrical Installations - All additional electrical work needs written permission and must be done and certificated by a government-authorised electrical contractor.
- Gas installations - You may only install a gas cooker provided a Gas Safe registered gas engineer does all the work and you have obtained written permission from us.

You must not install any other type of gas appliance. We will not repair or maintain anything you have replaced or added.

At the end of your tenancy you may be entitled to compensation for some approved improvements.

Please ask for information.

QUALITY CONTROL

We will inspect a proportion of repair jobs when they are completed, and instruct the contractor to remedy any unfinished or poor quality work.

Your feedback is really important to us and you can help us monitor and improve the service we provide by returning the repair satisfaction slip or questionnaire we send you.

ACCESS AND APPOINTMENTS

You must allow reasonable access to our contractors to ensure that the repair can be undertaken within our agreed timescales.

If the contractor makes an appointment with you for when they will call at your home to carry out the repair you must keep the appointment or give us reasonable notice if you cannot keep the appointment.

By law we must carry out gas safety checks every 12 months on any gas appliances and pipes that

we provide in your home. If you do not allow us access to carry out the work then we will take court action to gain access.

CODE OF CONDUCT

We require contractors to ensure that works are carried out with the minimum of disruption to you.

They are required to:

- Introduce themselves to the customer and show proof of identity. Do not hesitate to ask to see it and refuse entry if it is not provided.
- Explain the nature and purpose of the job.
- Behave in a proper and professional manner at all times, refrain from smoking, bad language and playing radios.
- Take care of the customer's property and possessions and protect them at all times from dust, paint etc.
- Keep the customer's home secure at all times.
- Keep safe all materials and equipment used on site to avoid

danger to occupants and visitors.

- Reconnect and test services such as water, gas and electricity at the end of each working day.
- Clear any rubbish arising from works to the property, garden or other areas outside the property.
- Make good any damage to decorations.
- Comply with health and safety legislation and relevant codes or practice.
- Comply with our equality and diversity policy.
- Where major works are involved, agree the extent of removal of carpets, furniture etc, and their condition before the work commences.

COMPLAINTS

We are committed to providing a high standard of service to our customers. However, if you think we have failed to provide a satisfactory service, you should make use of our complaints procedure, which is designed to

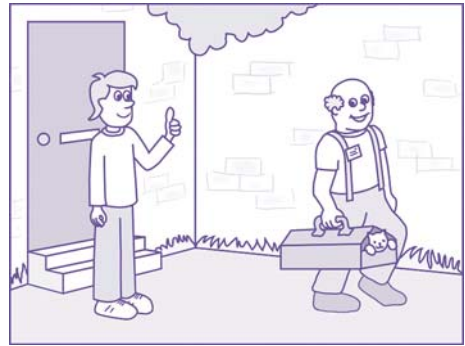

resolve complaints as quickly as possible.

In the first instance you should ring us on 0800 111 4013 and tell us about your complaint. If you are dissatisfied with the response you receive, you should follow our complaints procedure.

In certain circumstances you can apply for compensation if we fail to meet satisfactory standards.

If you have any problems about our repair service please ring us in the first instance on 0800 111 4013. If you remain dissatisfied you may wish to use our complaint procedure.

| Repair | | Responsibility | |
|-----------------------------------|--|----------------|-----|
| | | Us | You |
| Baths | Except unblocking wastes | ✓ | |
| Bathroom fixtures and fittings | Except WC seats, bathroom cabinets, mirrors, towel rails and toilet roll holders | ✓ | |
| Boundary walls and fences | | ✓ | |
| Carpentry | | ✓ | |
| Chains and plugs | On basins, baths and sinks | | ✓ |
| Chimneys | | ✓ | |
| Communal areas | | ✓ | |
| Decoration (external) | | ✓ | |
| Decoration (internal) | Except when damage is caused by a structural defect | | ✓ |
| Domestic appliances | Such as cookers, fridges, washing machines, dishwashers | | ✓ |
| Doors (external) | Includes frames, hinges, locks, door jambs, thresholds, letterboxes and handles | ✓ | |
| Doors (internal) | Includes frames and hinges only (easing and adjusting is your responsibility) | ✓ | |
| Drains, gutters and outside pipes | | ✓ | |
| External door locks | Except where replaced due to loss of keys | ✓ | |
| External timbers elements | | ✓ | |
| Fences and gates | | ✓ | |

| Repair | | Responsibility | |
|----------------------------------|--|----------------|-----|
| | | Us | You |
| Fire grates, flues and surrounds | Only if installed by us | ✓ | |
| Fixtures and fittings | Such as coat hooks, curtains, curtain rails | | ✓ |
| Floor boards | | ✓ | |
| Floor covering | Including adapting doors to accommodate carpets | | ✓ |
| Front and back door locks | Includes communal locks | ✓ | |
| Garages | | ✓ | |
| Gardening maintenance | Including dustbins and refuse areas | | ✓ |
| Gas | | ✓ | |
| Glazing | If broken into you must get a crime number from the police | | ✓ |
| Hand basins | Except blockages | ✓ | |
| Heating | Including storage heaters and fitted electric fires. Except bleeding radiators | ✓ | |
| Hot water heaters | Including cylinder jackets | ✓ | |
| Immersion heaters | | ✓ | |
| Infestations | By ants, wasps, bees, cockroaches, mice, rats or bedbugs | | ✓ |
| Internal door handles and locks | | | ✓ |
| Kitchens | Except domestic appliances | ✓ | |
| Light fittings | Except light bulbs, dimmer switches, fuses, fluorescent tubes and starters | ✓ | |

| Repair | | Responsibility | |
|----------------------------|--|----------------|-----|
| | | Us | You |
| Loss of keys | Including repairs to forced entry if you get locked out | | ✓ |
| Mains wired smoke alarms | | ✓ | |
| Out-buildings | Only if provided by us | ✓ | |
| Paths | Including steps, footpaths and ramps | ✓ | |
| Plastering | | ✓ | |
| Plumbing repairs and leaks | Except for washing machines and dishwashers and bleeding radiators | ✓ | |
| Porches | Except glazing | ✓ | |
| Re-lighting pilot lights | Including the resetting of any heating controls or programmers | | ✓ |
| Re-washer taps | | | ✓ |
| Roofs | | ✓ | |
| Sink units | Except blockages | ✓ | |
| Skirting boards | | ✓ | |
| Stairs | | ✓ | |
| Switches and sockets | Except dimmer switches | ✓ | |
| Telephone points | | | ✓ |
| TV aerials and sockets | Unless communal | | ✓ |
| Washing lines | Except in communal drying areas | | ✓ |
| Waste blockages | Including basins, bath, WCs | | ✓ |
| WC seats | | | ✓ |
| Windows | Including window sills, catches, sash cords and frames | ✓ | |
| Worktops | | ✓ | |

EMERGENCIES

Fire

- Dial 999. Get everyone out and do not go back for any reason (unless you live on a shelter scheme and you should follow the procedure set for your scheme).
- Close all doors and windows.
- Warn your neighbours if any of them might be in danger.

If you smell gas

- Open the doors and windows to get rid of the gas.
- Check to see if the gas has been left on unlit, or a pilot has gone out. If so turn the appliance off and do not try to relight it until all smell of gas has been cleared from the property.
- If the leak cannot be stopped by turning off an appliance, or you are uncertain whether it has been stopped, turn the main gas supply off at the meter and phone the gas emergency

service immediately – National Grid 0800 111 999.

- Do not turn any electrical switches on or off. Do not use doorbell.
- Do not smoke.
- Do not use matches of naked flames.

Burst or leaking pipe

- Turn the water off at the mains.
- If electrics are affected, turn off the electricity at the consumer unit. See page 74 for more advice.
- Call our repairs service on 0800 111 4013.

Loss of electricity

- If neighbours are also affected, call your electricity company (find the number on your electricity bill). Otherwise, see advice on page 76.
- If the problem persists after following the advice on page 76, call our repairs service on 0800 111 4013.

BATH

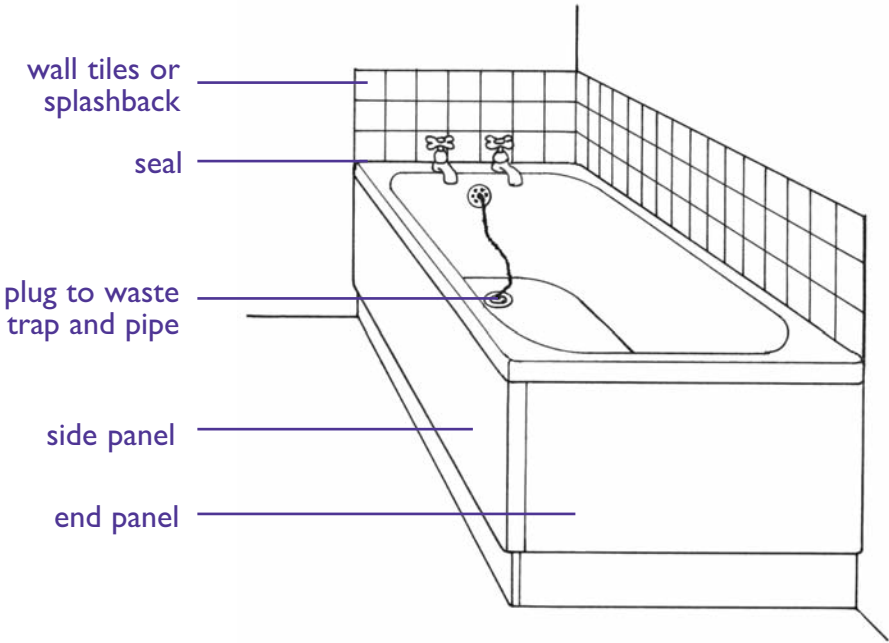

WASTE TRAPS

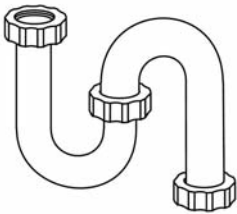

'S' trap

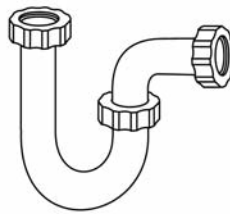

'P' trap

'P' trap with washing machine connection



Bottle trap



Before you contact us...

- If water is near electrics, do not touch. Turn electricity off at consumer unit main switch.
- Stop leak causing more damage.
- Can you clear blockage yourself?
(see Tips page 79)

Tell us...**Bath/basin water leaking**

- Are electrics affected?
- Where is leak? (bath or basin)
- What is affected? (waste pipe/trap, pipe or tap. See page 16/18)
- If pipework is affected, is it hot or cold supply pipe, or waste trap?

Bath/basin blocked

- What is blocked? (bath or basin)
- What caused the blockage?

Bath or basin damaged/broken

- What is damaged? (bath or basin)
- What is affected part made from? (metal, plastic or china etc)
- If a bath panel is affected, which panel (side or end panel) and what is it made from (hardboard or plastic)?
- Does it need to be replaced or refixed?

BASIN

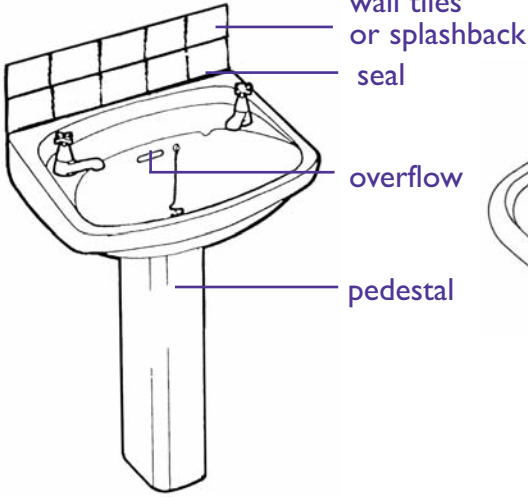

POP UP WASTE

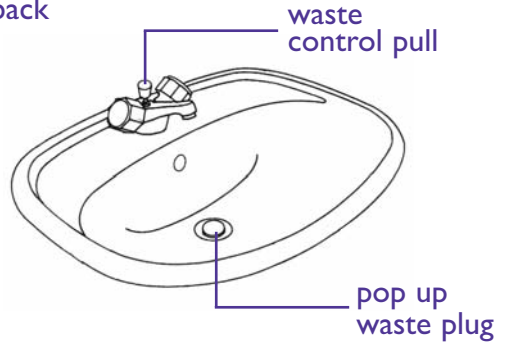

TYPES OF TAPS

Standard pillar tap



High neck pillar tap



Modern pillar tap

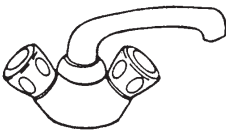

Mixer tap



Bib tap



Supatap

Before you contact us...**Tell us...****Damaged wall tiles**

- Where are tiles?
- Are they loose, broken or damaged?
- How many are affected?
- What size and colour are they?
- How did it happen?

Bath panel loose

- Which bath panel is affected?
(side or end panel)
- What is it made from?
(hardboard or plastic)

Seal gone around bath**Seal gone around basin****Bath tap dripping**

- What type of tap is it?
(see diagrams page 18/20)

Basin tap dripping

- What type of tap is it?
(diagrams opposite)

Tap loose

- Bath or basin tap?
- What type of tap? (see diagrams opposite)

Plug/chain required

- Is it on bath or basin?

SHOWER

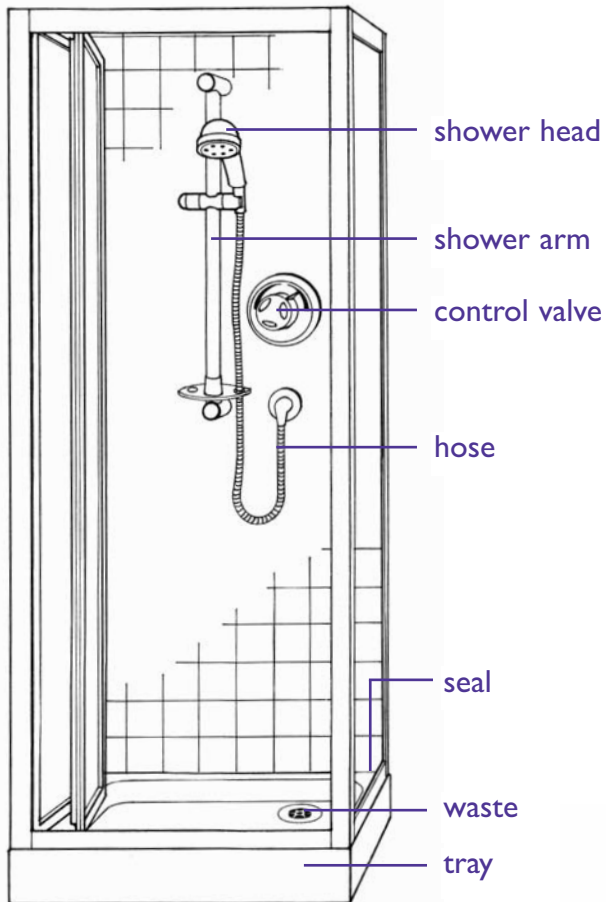

CEILING PULLCORD POWER SWITCH For electric shower

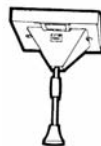

ELECTRIC SHOWER

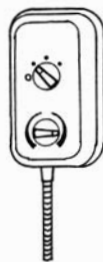

BATH / SHOWER MIXER TAP

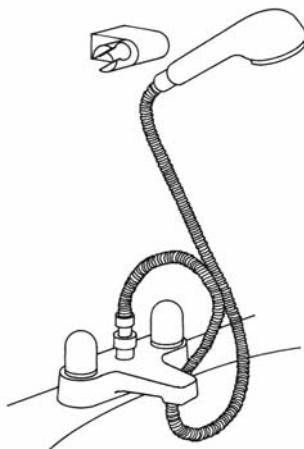

Before you contact us...

- If it is your own shower, this is your responsibility.
- If electric, check power is switched on (by cord or switch) and controls are set correctly.
- If it is your own shower curtain, this is your responsibility.
- If limescale is the problem, use descaler fluid which can be bought from a DIY shop.

Tell us...**Seal gone around shower tray****Shower tray broken**

- What is it made of? (ceramic or plastic)

Shower not working

- What type of shower is it? (electric or connected to the central heating. See diagrams opposite)
- What is happening? (no water, or only hot or cold water)
- Do you have hot water in rest of home?
- Can you see a make or model number on shower?

Shower curtain damaged**Shower switch broken****Shower hose broken**

- How did it happen?

Shower blocked

- What is causing blockage?

Shower arm broken

- How did it happen?

WC

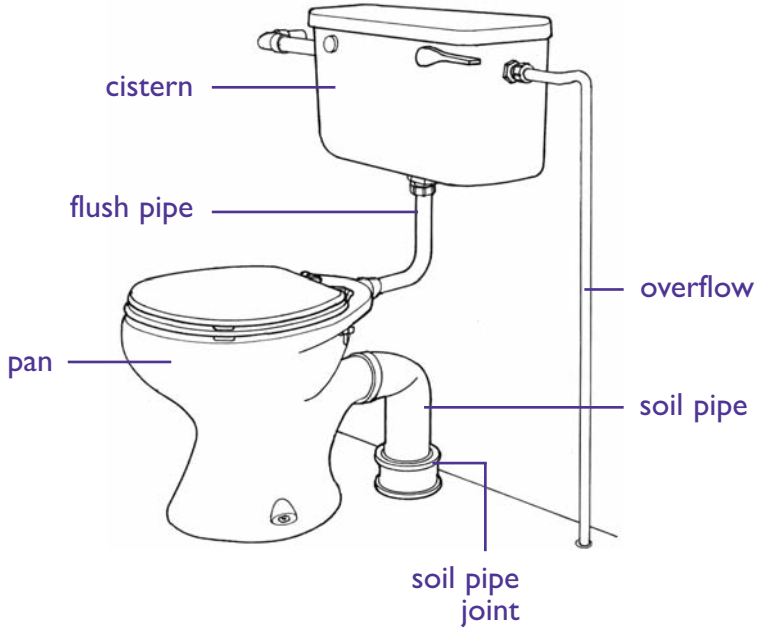

CISTERN

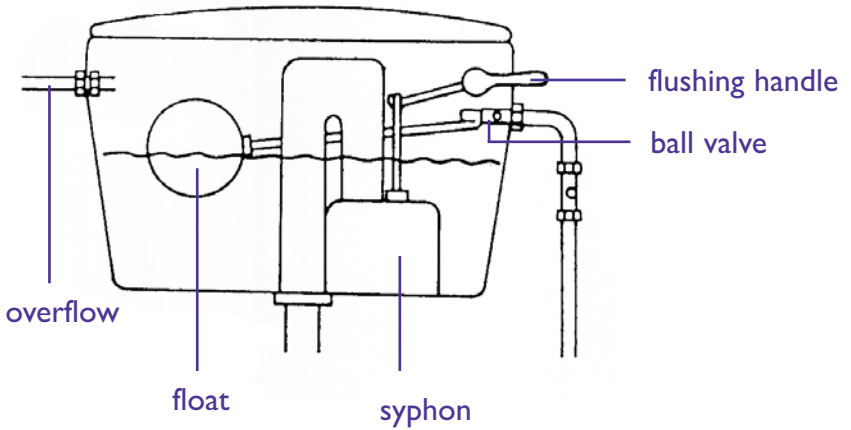

Before you contact us...

- Has water authority said that water would be going off?
- You can use a bucket of cold water to flush until problem is fixed. If cistern is not filling, lift lid and see if anything is stopping the float from working. Try moving the float up and down to see if it will fill.
- Try to stop leak and any damage it is causing.
- If serious, turn off water at stopcock and gate valves from cold water tank. Open all taps to drain water from system. Turn off heaters affected.

Tell us...**Damaged wall tiles**

- Are tiles loose, broken or damaged? How many are affected? What size and colour are they? How did it happen?

Cubicle door not working

- Is it broken or stuck?

WC will not flush

- Is the handle or chain moving properly?
- Is the float still working?

WC leaking

- Where is leak? (pan, cistern, overflow, supply, flush or waste pipe or pipe joint. See diagrams opposite)
- If leak is from cistern, is it high or low level cistern? (See diagrams page 24)
- Is affected part loose, cracked or broken
- Is it your only WC?
- Is it a coloured WC or white?

TYPES OF WC

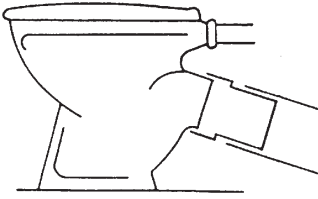

'P' type waste trap

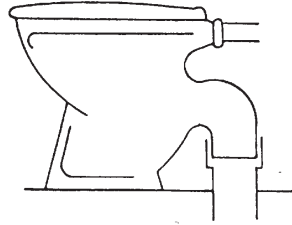

'S' type waste trap



Low level cistern

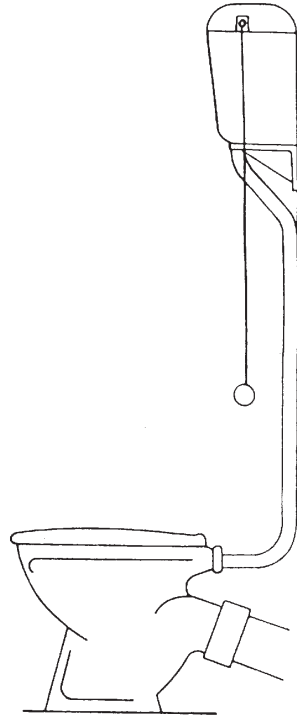

High level cistern

Before you contact us...

- As a temporary solution, tie float in the up position, thus closing the ball valve (see page 80 for help).

Tell us...**Overflow running**

- Does the overflow run outside?
- Is the cistern flushing?
- Is the float working?
- Is overflow running continuously?

Seat damaged

- Is it broken, damaged or missing?
- What is it made from? (plastic, wood etc)
- What colour is it?

Soil stack blocked

- Do you live in a house or flat?
- If a flat, which floor are you?
- Is your WC causing the blockage?

WC blocked

- What caused blockage?

- Try unblocking it yourself by removing excess water into a bowl, and using a toilet brush or plunger (without metal disk). (See page 80 for help)

WATER SYSTEM IN A TYPICAL HOUSE

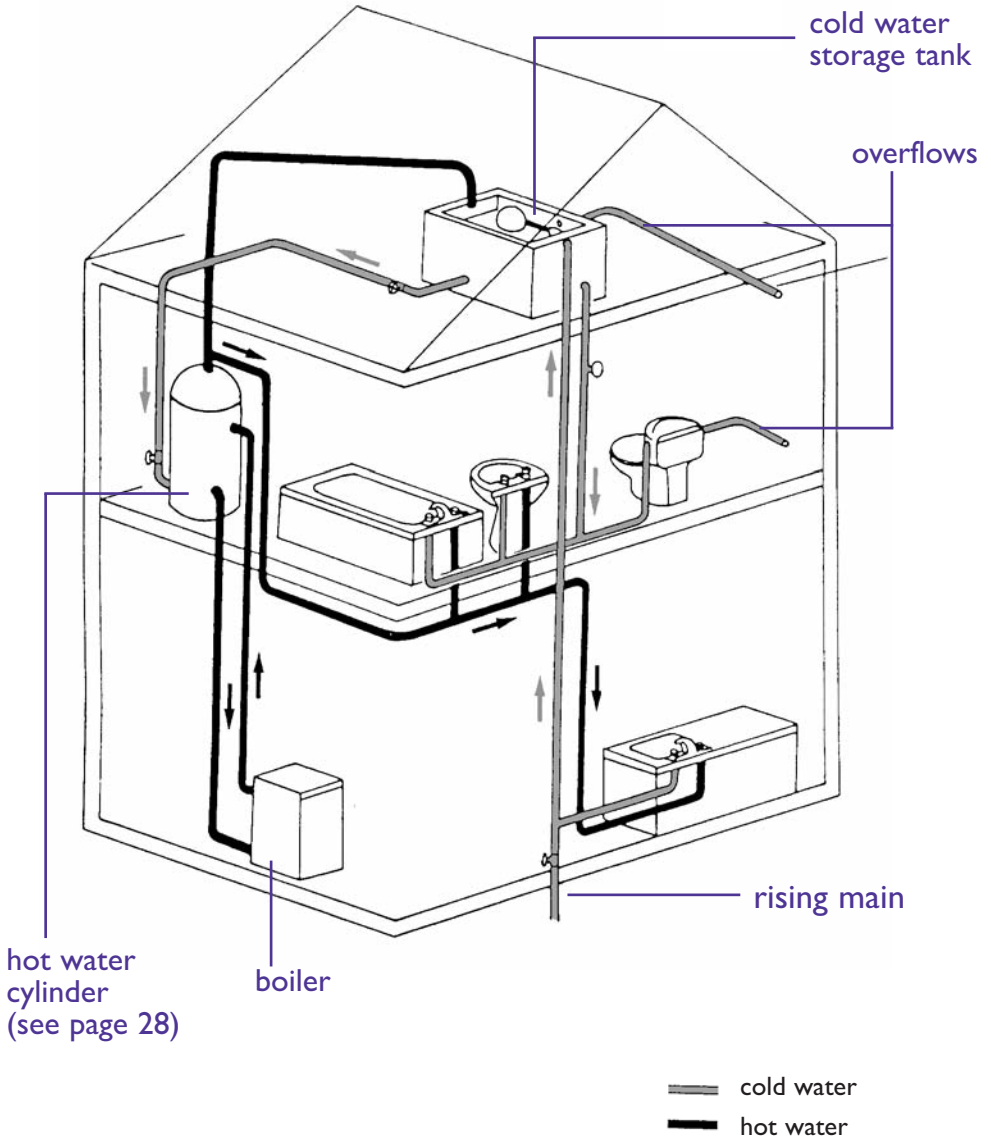

Before you contact us...

- If water is near electrical fittings, turn off electricity at consumer unit main switch. (See page 76)
- Can you stop leak or isolate it? Try to catch water in a bowl or bucket. (See page 73 for help)
- Adjust main stopcock where water comes into home.
- Are neighbours affected?
- Make sure taps are turned off, even though no water is coming through.

Tell us...**Burst pipe**

- Are electrics affected by burst?
- Is it inside or outside building?
- Are pipes frozen?

Water leaking**Banging pipes**

- How often is it happening?

No cold water

- Is there cold water at kitchen sink?
- Are pipes frozen?

Storage tank overflow running

- Is overflow running outside?
- See page 80 for Helpful Tips

HOT WATER CYLINDER

GAS BOILER

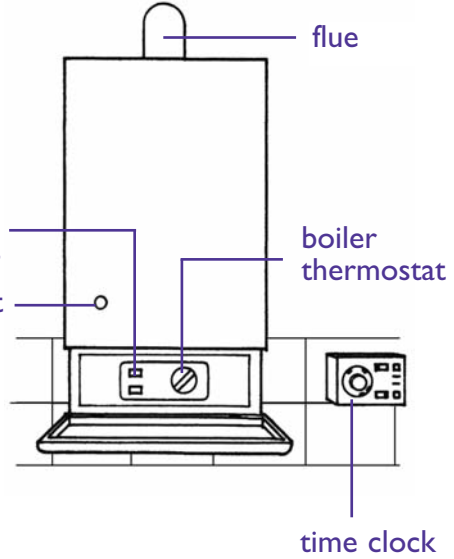
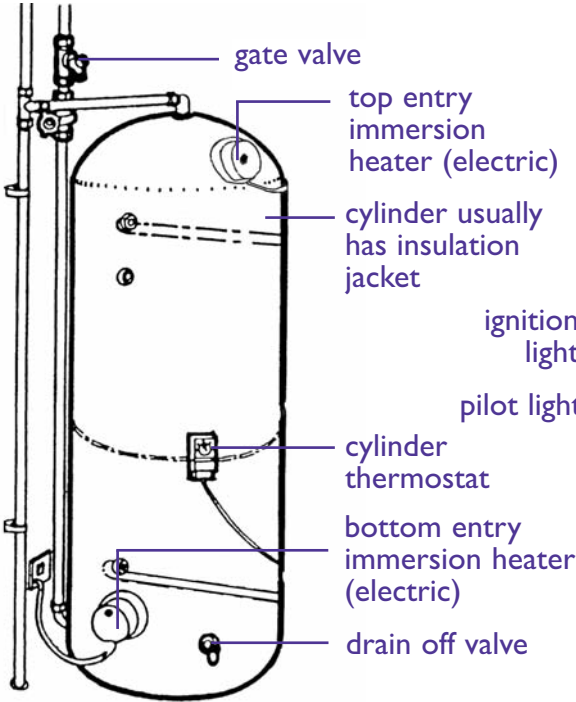

TYPES OF WATER TEMPERATURE CONTROLS

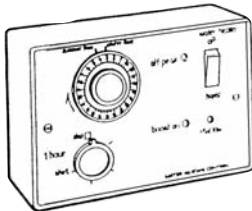

Economy 7 controller for water heater

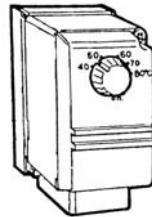

Cylinder thermostat

Before you contact us...

- If gas, check time clock controller is set for hot water and timer is set correctly.
- If electric, is there a power cut? Are neighbours affected? If so, contact your electricity company (check your electricity bill for the number).
- If coin or credit meter, has it has run out of credit?

Tell us...**No hot water**

- What heats water? (gas, electric, or solid fuel)
- If electric, are other electrical facilities working?
- Are heating controls set correctly?
- Is room heating still working?
- Do you have alternative source of hot water? (immersion heater or gas heater etc)
- Do you have a hot water cylinder?

DOOR ENTRY CALL UNIT

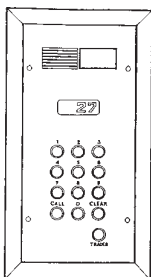

DOOR ENTRY PHONE IN FLAT

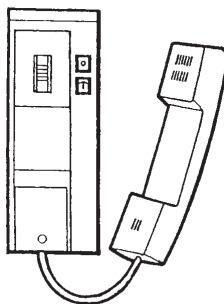

OUTSIDE LIGHT

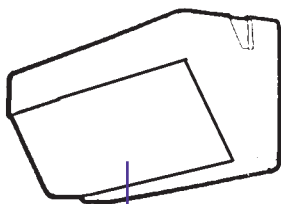

removable cover

METAL HOPPER TO REFUSE CHUTE

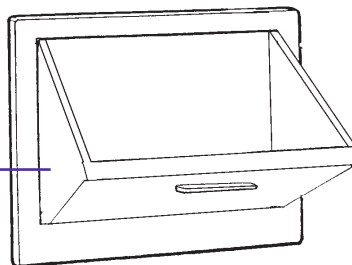

hopper door

Before you contact us...

- If door is jammed, see page 33.
- Is power cut causing the problem. If so, contact electricity company (check your electricity bill for the number).

Tell us...**Door entry faulty**

- Has whole system failed, or is only your home affected?
- Is fault at entrance or your phone?
- Is door jammed?

Emergency lighting faulty

- Which lights are affected?
- Is it failing to turn off or not coming on?
- Is fire alarm ringing?

Communal lighting faulty

- Which lights are affected?
- Is it on all the time?
- Does it not come on at all?

Rubbish chute faulty

- What is wrong? (chute is blocked, broken etc)

Communal TV aerial faulty

- What is the nature of the problem?

EXTERNAL DOOR

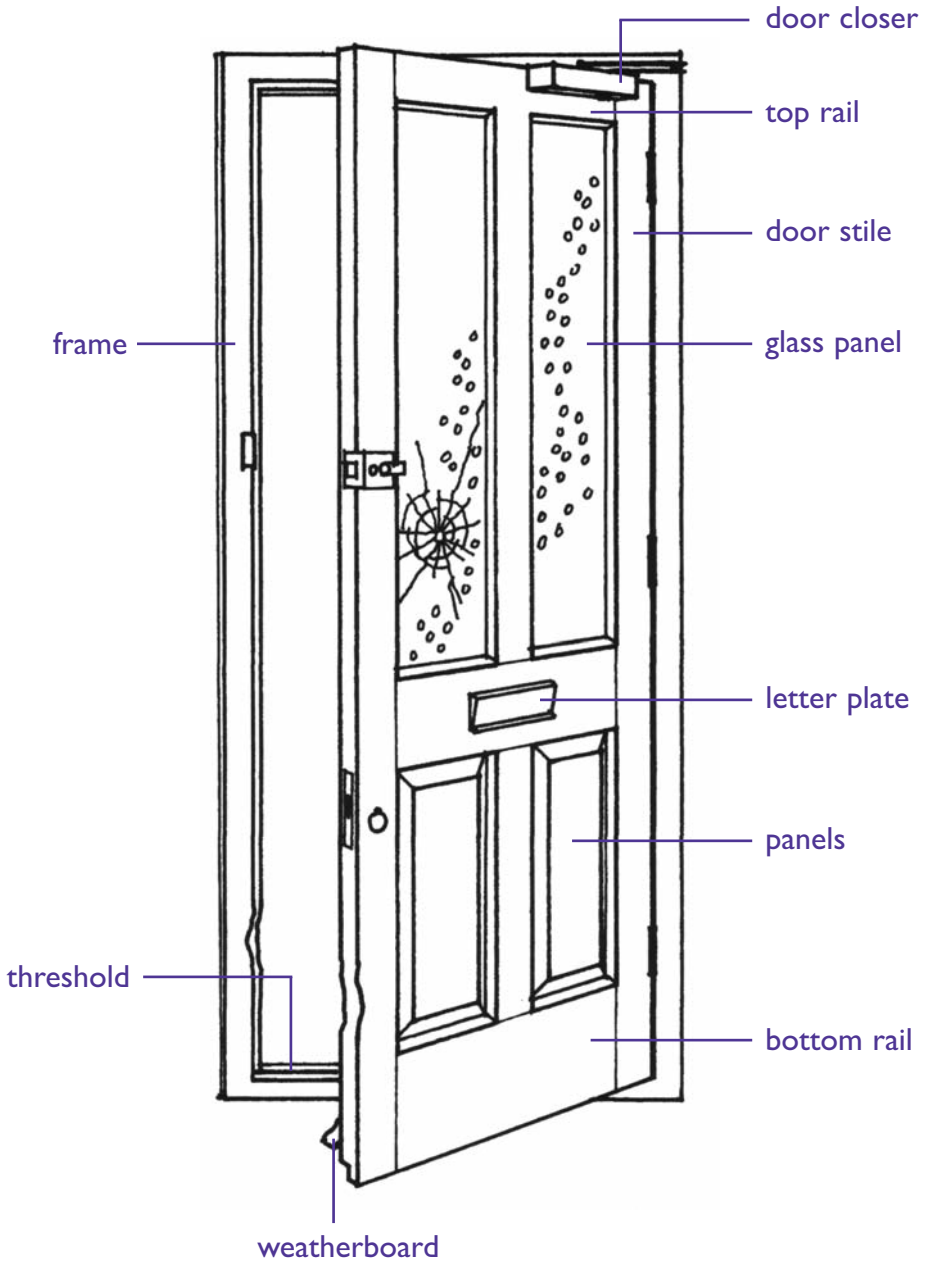

Before you contact us...**Tell us...****Door jammed**

- Is it front or rear door?
- What type of door is it?
(See diagrams on page 34)
- What is door made of?
(wood, metal or plastic etc)
- Is door jammed open or closed?
- Can you still get in and out of your home?

Door frame damaged/rotten

- Is door or frame affected?
- Is it front or rear door?
- What type of door is it?
(See diagrams on page 34)
- What is door made of?
(wood, metal or plastic etc)
- What is wrong with it?
(damaged or rotten)
- Is home insecure as a result of this problem?

Threshold rotten/needs repair

- What type of door is it?
(See diagrams on page 34)
- What is it made from?
(wood, metal etc)
- What is wrong with it?
(rotten, broken etc)

TYPES OF EXTERNAL DOORS

Panelled

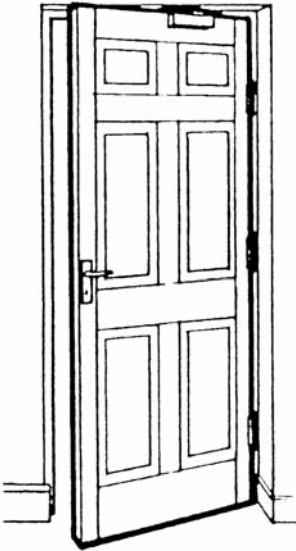

Panel & glazed

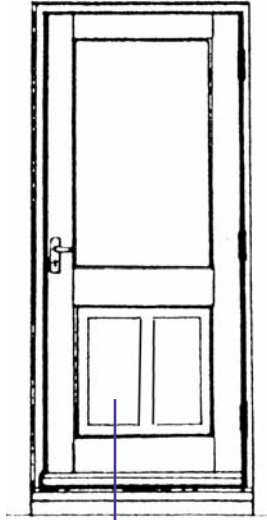

glass

Fully glazed

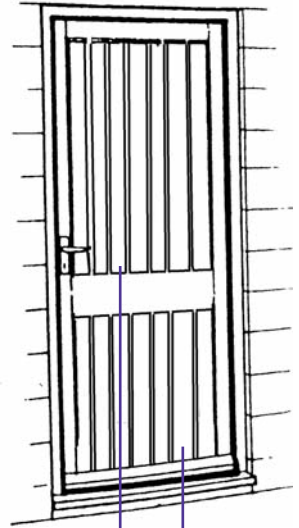

glass

RIM NIGHT LATCH Double security

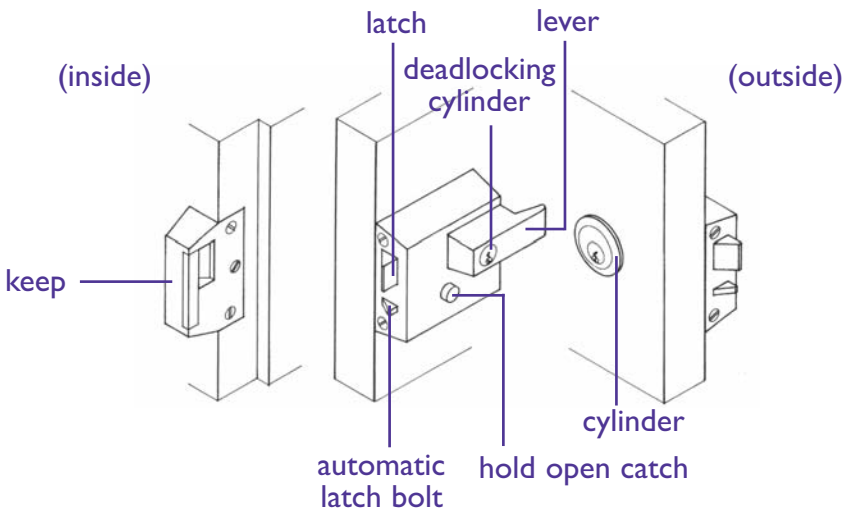

Before you contact us...**Tell us...****Weatherboard rotten/broken**

- What type of door is it?
(See diagrams opposite)
- What is it made from?
(wood, metal or plastic)
- What is wrong with it?
(rotten, broken etc)

Glass damaged

- What type of door is it?
- If fully glazed, which panel(s) is damaged?
- Is it your own door or a communal one?
- Is it front or rear door?
- Is it single or double glazed?
- What type of glass is it?
(clear, wired or obscure)
- Is your home secure?

Draught coming around door

- Where is draught coming from?
(between wall and frame, around door or under door)
- Is there any draught proofing around door?

Rain coming in under door

- Does door have a weatherboard? (See diagram on page 32)

MORTICE DEADLOCK

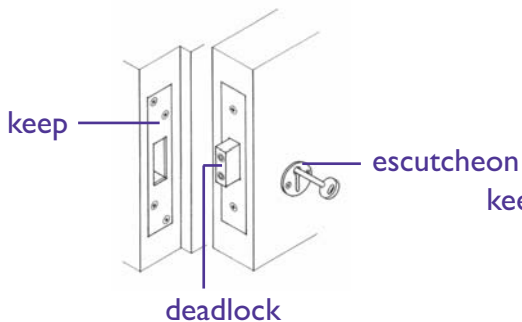

RIM LOCK

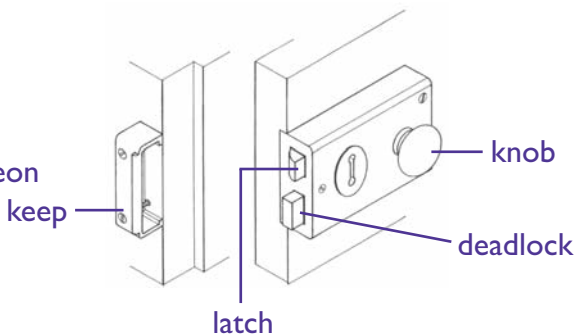

MORTICE CLAW BOLT DEADLOCK For sliding doors

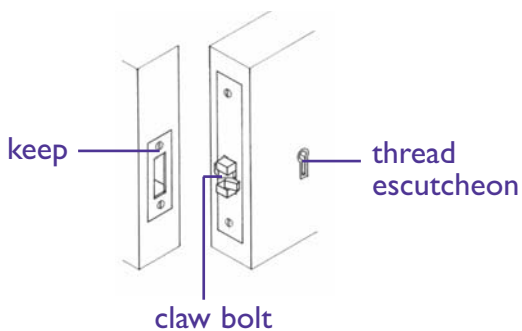

INTERNAL DOOR LATCH

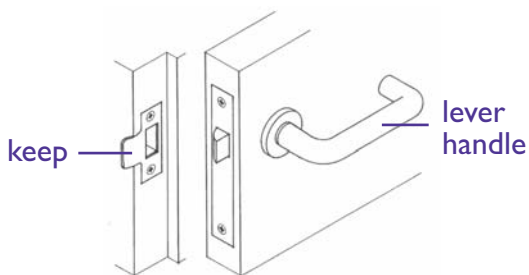

MORTICE SASH LOCK

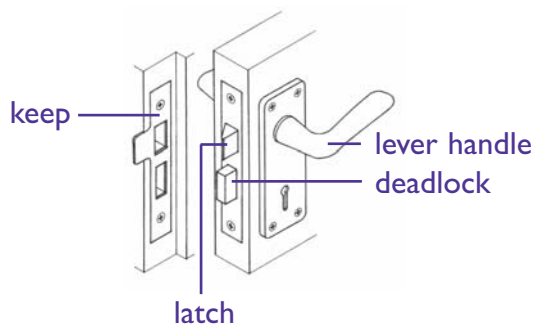

OUTSIDE DOOR PULL

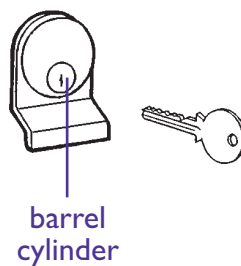

Before you contact us...

- Tenant's own locks are your own responsibility.
- This is usually your own responsibility.
- Tenant's own fittings are your own responsibility.

Tell us...**Door lock not working**

- What type of lock is it?
(See diagrams opposite)
- What is wrong with lock?
(lever handle faulty, spring worn out, striking plate out of place or lock not fitting into keep etc See diagrams opposite)
- Which door is affected?
- What is door made of?
(wood, metal or plastic)
- Is your home secure?

Keys lost/locked out

- Are you locked out of your home?
- What type of lock is it?
(See diagrams opposite)
- Where is door? (front, rear, patio or store)

Ironmongery missing/not working

- What fitting is it? (letterplate, handle, chain, door viewer, house numbers etc)
- Is door not closing properly?
- Is your home insecure?

SASH WINDOW

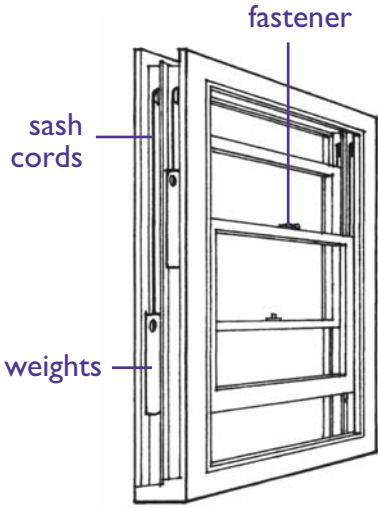

CASEMENT WINDOW

As seen from outside

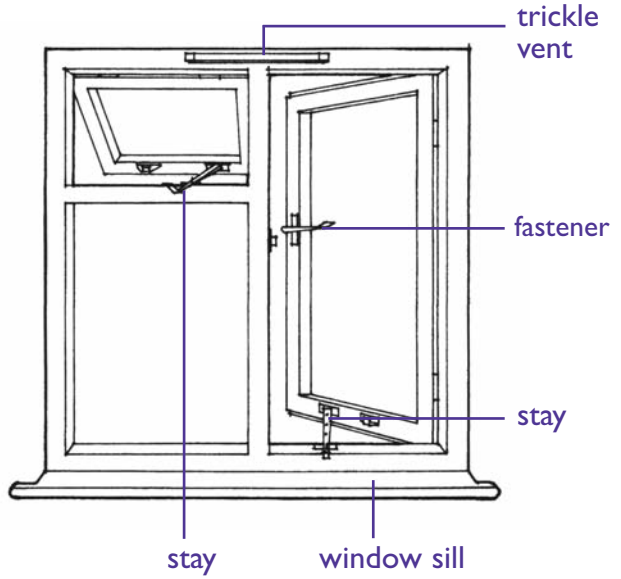

TILT & TURN WINDOW

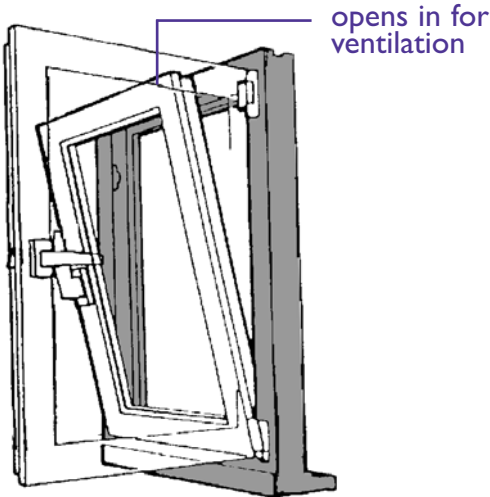

PIVOT WINDOW

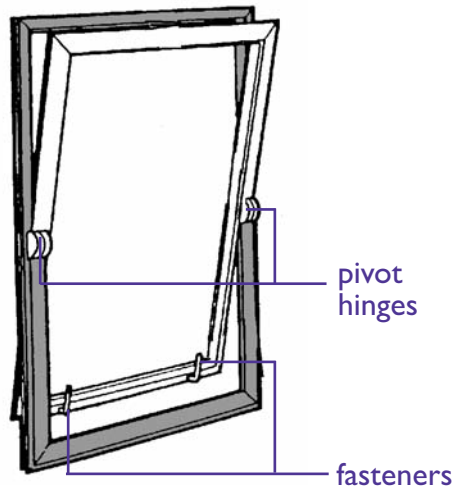

Before you contact us...

- If you can do it safely, remove any loose broken glass which could be dangerous to others, and wrap it in newspaper before binning it.

Tell us...**Glass damaged**

- Is it single or double glazed?
- Where is window? (which floor of the building, a communal window or one to your home)
- What type of glass is it? (clear, wired, or obscure)
- What is window frame made of? (wood, metal or plastic)
- Is your home secure?

Window frame jammed

- What is frame made of? (wood, metal, or plastic)
- What type of window is it? (sash, pivot or tilt window etc. See diagrams opposite)
- What is causing problem? (rotten wood, hinges or sash cord broken etc. See diagrams opposite and page 40)
- Is your home secure?

FITCH SASH FASTENER

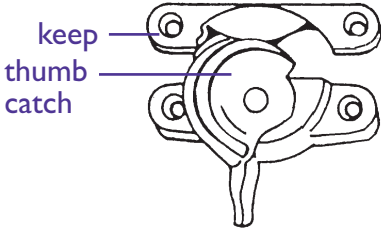

BRIGHTON SASH FASTENER

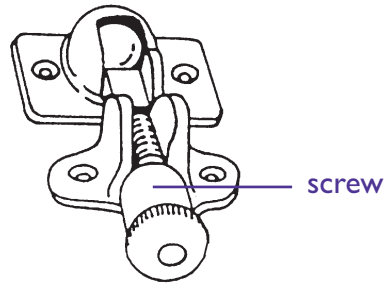

HOOK CASEMENT FASTENER

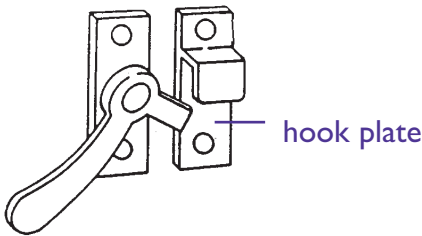

RESTRICTOR STAY Prevents window opening fully

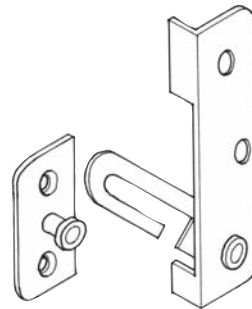

CASEMENT STAY

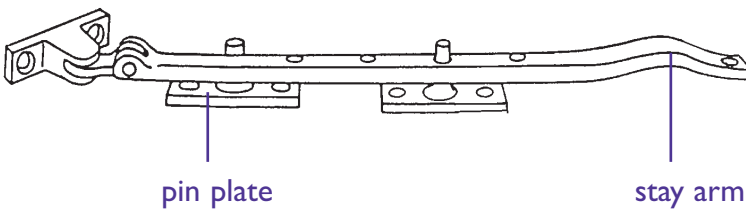

Before you contact us...**Tell us...****Ironmongery defective**

- What type of window is it?
(sash, pivot or tilt window etc
See diagrams page 38)
- What is frame made of?
(wood, metal or plastic)
- What part is defective?
(stay, catch, fastener or lift etc
See diagrams opposite and
page 38)
- Is your home insecure?

TYPES OF FENCE

Pallisade

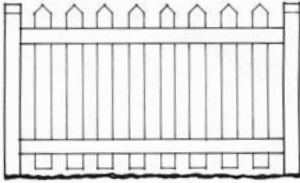

Chainlink

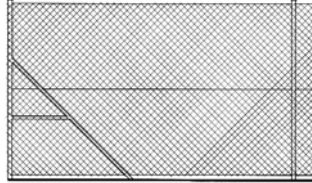

Chestnut pale

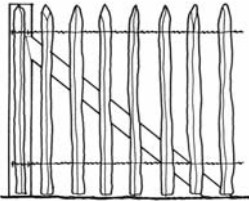

Close boarded

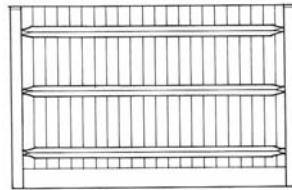

Interwoven

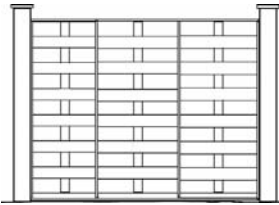

Hit & miss

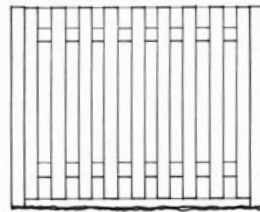

Post & wire



Concrete post & timber panelled

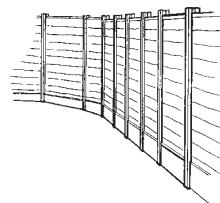

Before you contact us...**Tell us...****Fence dangerous/broken**

- Where is fence? (front, rear or side)
- What kind of fence is it? (boarded, chestnut pale, timber pallisade, ranch style etc. See diagrams opposite)
- What are posts and panels made of? (wood or concrete)
- Does it need to be replaced or resecured?
- Is it your own fence or shared with your neighbour?
- How many panels are affected or what is the length of affected fencing?

See page 48 for gates.

UP & OVER GARAGE DOOR

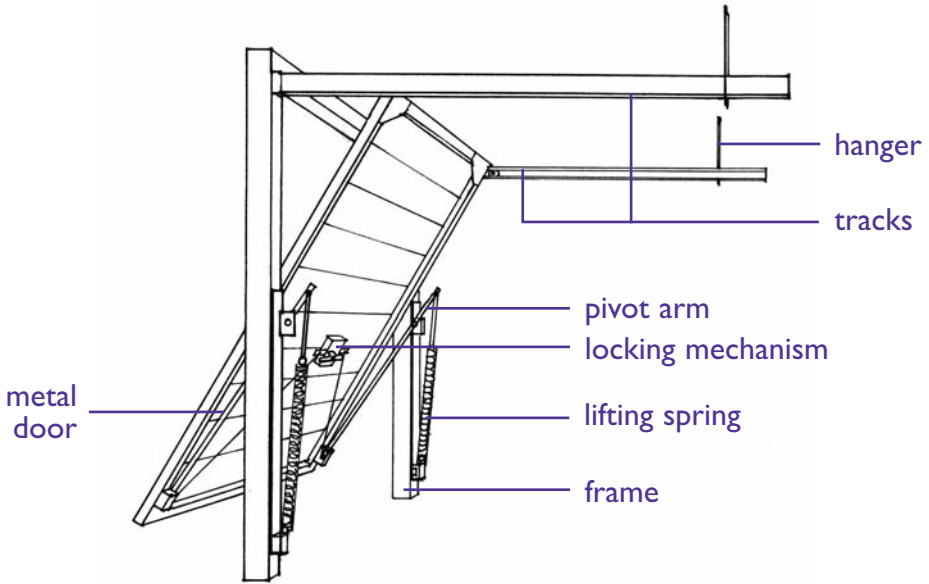

GARDEN

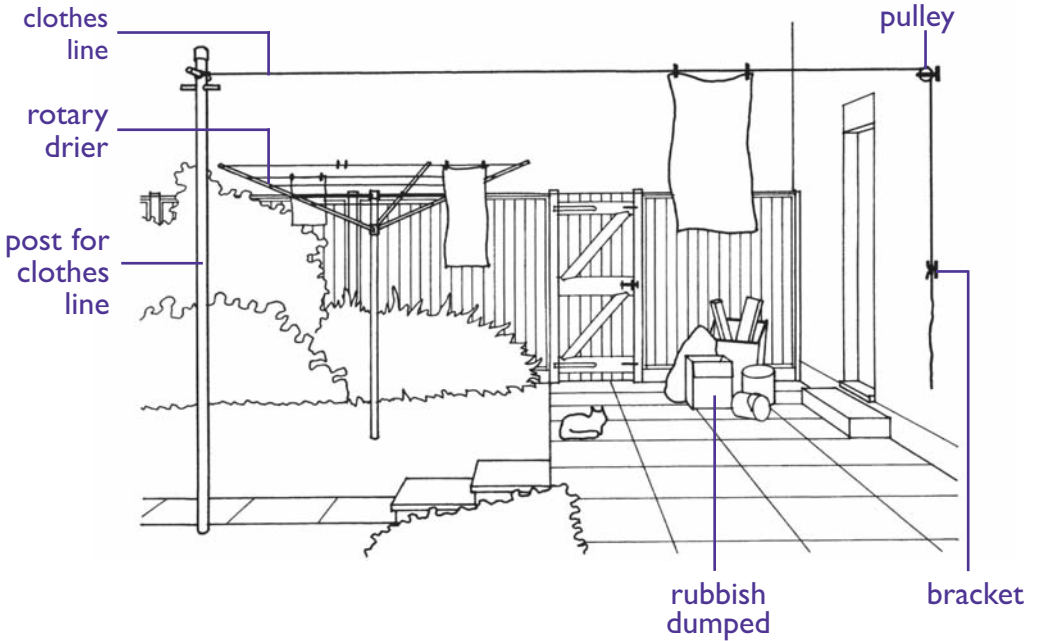

Before you contact us...**Tell us...****Garage door faulty**

- What type of garage door is it?
- What is door made from? (wood, metal etc.)
- What is the problem? (door or frame is loose, damaged or off mechanism, lock is broken or keys are lost etc)

Rubbish dumped in garden

- What sort of rubbish?
- Who put it there?
- Is it hazardous?

Clothes post broken

- What is it made of? (concrete or metal etc)
- How was it broken?

Clothes line broken

- What type of clothes line is it?
- Is pulley or bracket broken

Clothes line stolen

- What type of clothes line is it?

PAVING & STEPS

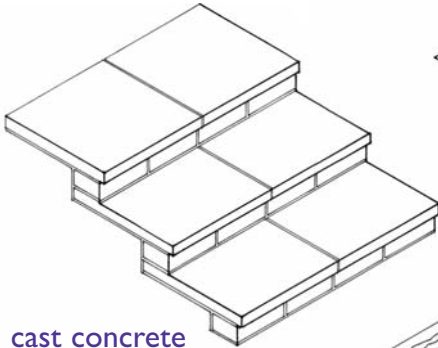
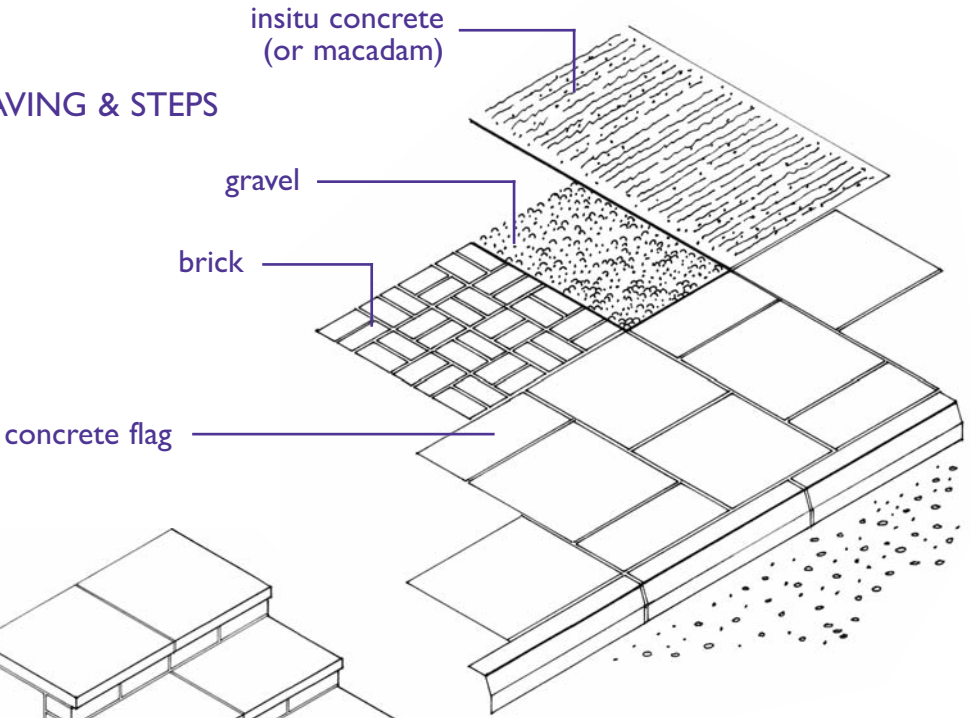

Pre cast concrete steps on brick

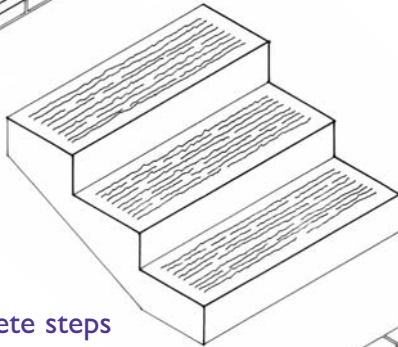

Insitu concrete steps

TYPES OF STEPS

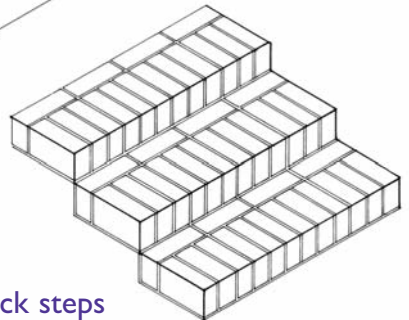

Brick steps

Before you contact us...

- If dangerous, warn others.
-
- If dangerous, warn others.

Tell us...**Paving damaged**

- Where is path? (front, rear or side)
- What type of path is it? (flag, concrete etc. See diagrams opposite)
- What is wrong with path? (paving stones/flags are broken or loose etc)
- Are paving stones/flags square or rectangular?
- How many are affected?
- Is it hazardous?

Steps broken

- Where are steps? (front or rear)
- What are steps made of? (concrete, brick, etc. See diagrams opposite)
- How many steps are affected?
- Is it hazardous?

Gate broken/rotten

- Where is gate? (front, side or rear)
- What type of gate is it? (single or double etc. See diagrams page 48)
- What is gate made of? (wood or metal)
- Does it need to be replaced or resecured?

BRACED GATE

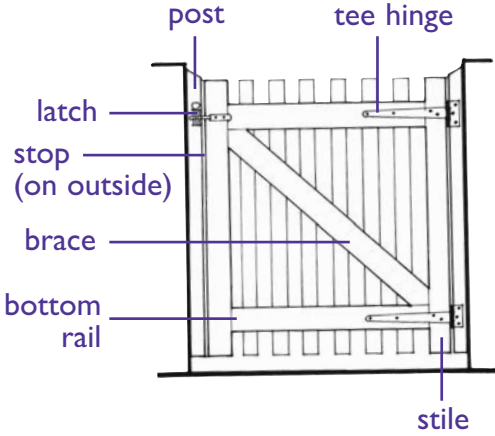

LEDGED & BRACED GATE

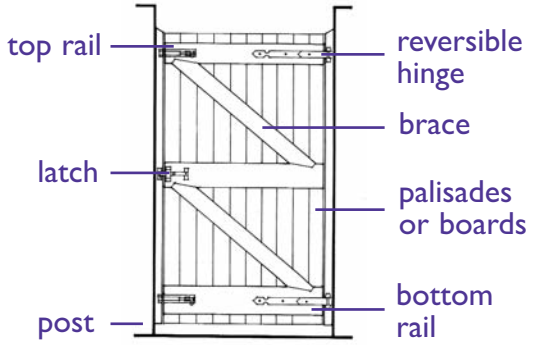

FREESTANDING WALLS

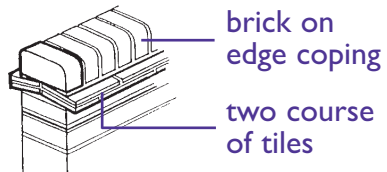
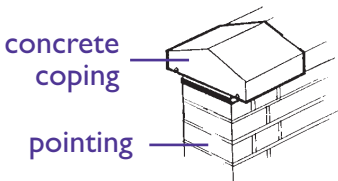
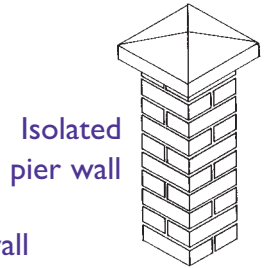
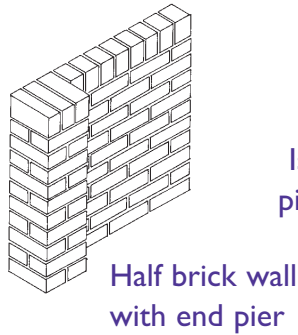
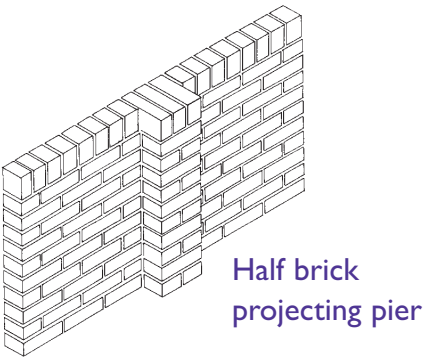

Before you contact us...**Tell us...****Gate jamming**

- What is gate made of? (wood or metal)
- What is causing it to jam? (hinge broken etc.)

Gate latch/bolt broken

- What type of latch is it?
- What is gate made of? (wood or metal etc)

Gate post rotten/broken

- What is post made from? (wood or concrete etc)

Gate post stop defective

- What is gate post stop made from? (wood or metal etc)

Wall dangerous/collapsed

- Is wall your own, or shared with a neighbour?
- What is wall made of? (brick or concrete etc)
- What part of wall is damaged? (pier, coping or pointing etc. See diagrams opposite)
- What caused the damage?

OUTDOOR ELECTRICITY METER

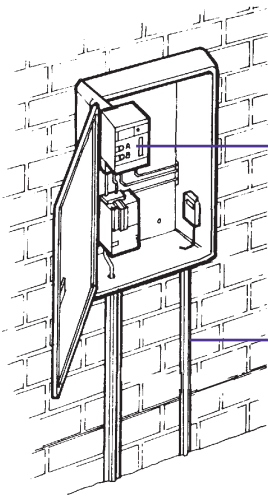

electricity meter

electricity supply

ELECTRICAL CONSUMER UNIT OR FUSEBOARD

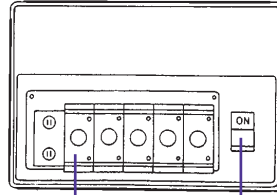

fuses or trip switches

main on/off switch

TRIP SWITCH
Replaces fuses in modern consumer units



FLUORESCENT LIGHTS

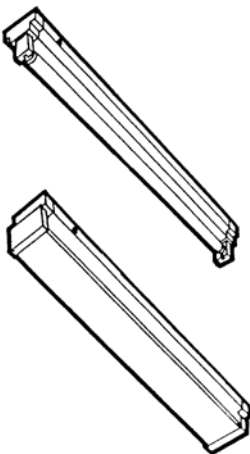

TYPES OF FUSES

Trip switch

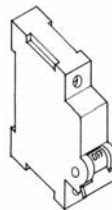

MCB

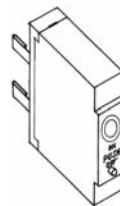

Cartridge type

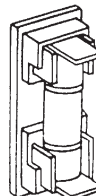

Rewirable type

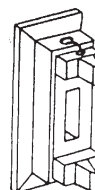

Before you contact us...

- If you have a coin or credit meter, check that it has credit on it.
- See if trip switch is activated or a fuse has blown on consumer unit. (See page 76 for help)
- Are your neighbours affected? If so, contact your electricity board (under 'electricity' in the Phone Book).
- Do not touch fitting.
- Turn electricity off at consumer unit main switch.
- See if trip switch is activated or fuse has blown on consumer unit. (See page 76 for help)
- Has bulb blown?
- Are power sockets working?

Tell us...**No power at all**

- Is yours the only property affected?
- Has trip switch been activated or a fuse blown on the consumer unit?

Fluorescent tube not working

- What is the problem? (tube flickers, broken etc)

Electrical fitting smoking

- What fitting is it? (light, plug etc)
- Where is it located?

Light circuit failed

- Are power sockets working?
- How many lights are affected?
- Is light fitting causing the problem? (the pendant, batten holder, wall or ceiling switch etc. See diagrams page 52)

SINGLE & DOUBLE SWITCHED POWER SOCKETS

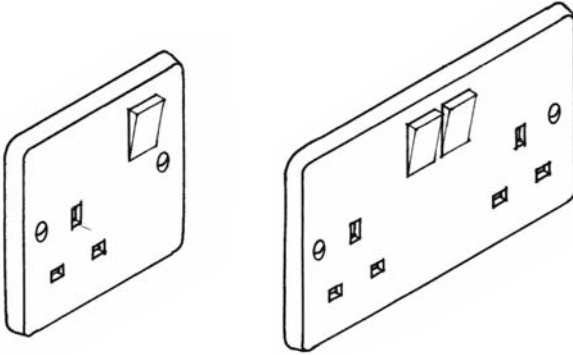

COOKER CONTROL POWER SOCKET

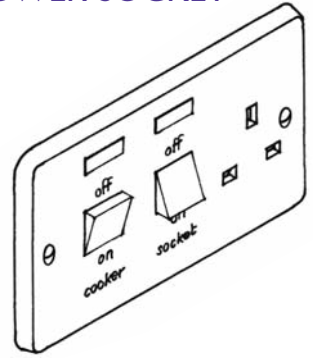

CEILING PULL SWITCH



PENDANT LAMP HOLDER

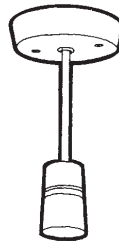

BATTEN LAMP HOLDERS



SMOKE DETECTOR/SMOKE ALARM

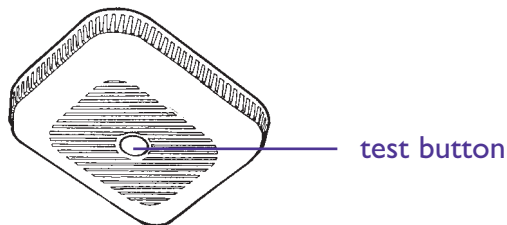

Before you contact us...

- Is it appliance rather than power socket that is faulty?
- Is trip switch activated or a fuse blown in the consumer unit? (See page 76 for help)
- Is there no power at all in your home? If so, see page 51.
- Tenant's own appliance is tenant's responsibility.
- Is it power socket rather than appliance that is faulty?
- Has fuse blown in the plug? If so, renew it with a suitably rated fuse.
- Is trip switch activated or a fuse blown in the consumer unit?
- Is there no power at all in your home? If so, see page 51.
- If it is battery operated, check batteries.
- If you have a warden, contact them.

Tell us...**Plug socket not working**

- Are other power sockets working?
- Is trip switch activated or a fuse blown in consumer unit?

Appliance not working

- Are other power sockets working?
- Is trip switch activated or a fuse blown in consumer unit?

Smoke detector defective

- Is it battery operated?
- Where is the smoke detector?
- What appears to be problem?

GAS BOILER

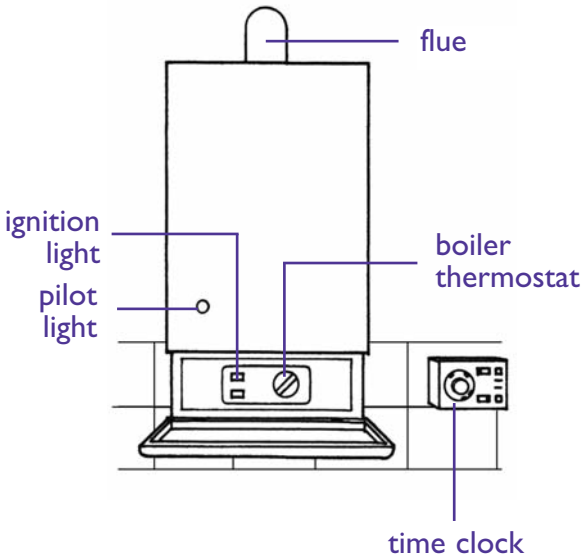

TYPES OF HEATING CONTROLS

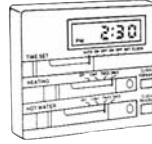

Digital programmer

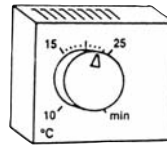

Room thermostat

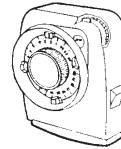

Clock programmer

EXTRACTOR FAN

Showing wiring to fused spur

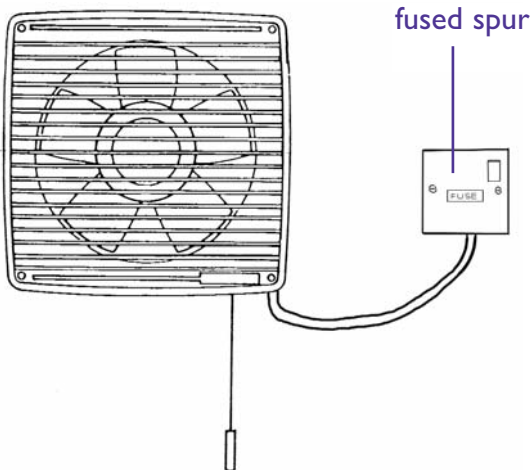

Before you contact us...

- If electric, check that power is still on, and that meter is still in credit.
- If gas, check pilot light is on.
- Check that boiler thermostat is set correctly (usually between 18°C and 22°C. See diagram opposite).
- Check that clock or digital timer is set correctly (see page 78 for help).
- Check that room thermostat is set correctly (usually between 18°C and 22°C).
- Are other flats affected?
- If you have a warden or caretaker, contact them.
- Check that thermostatic valve is turned up enough (see diagram opposite).
- Try bleeding radiator. (See page 75 for help)
- Is fan switched on?

Tell us...**Central heating boiler faulty**

- Is it your only source of heat?
- Do you have hot water?
- Can you see manufacturer's name and what model it is?

Communal heating faulty

- Is this your only source of heat?
- Is there any hot water?

Radiator not heating up

- Is thermostatic valve turned up enough?
- How many radiators are affected?
- Have you tried bleeding radiator(s) affected?
- Do you have hot water?

Extractor fan faulty

- Where is fan?
- What type of fan is it?

STORAGE HEATER

With convector

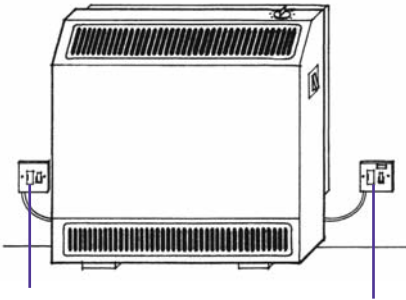

off-peak
supply for
storage
heater

supply for
convector

WALL MOUNTED CONVECTOR HEATER

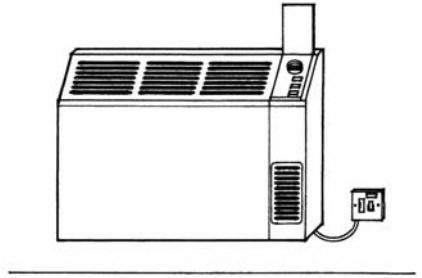

CENTRAL HEATING PUMP

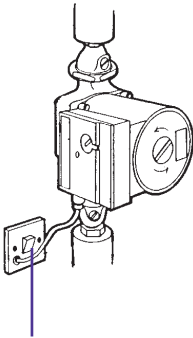

switched electric
power supply

PANEL RADIATOR

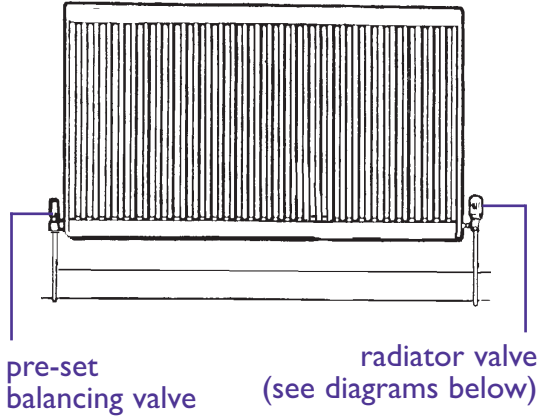

pre-set
balancing valve

radiator valve
(see diagrams below)

RADIATOR VALVES

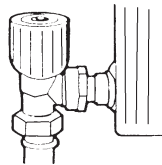

Manual
radiator valve

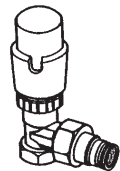

Thermostatic
radiator valve

Before you contact us...

- Try to stop leak causing damage.
- Turn radiator valve off.
- If gas leak , do not smoke, use matches, or turn electrical switches on or off. Open windows. Follow emergency action outlined on page 15.
- Turn off any appliances that are causing fumes.
- Make sure heater is turned on at socket.
- Check thermostat is set correctly.
- If no power in rest of home, see page 51.
- Check thermostat is set correctly.
- If faulty plug, see page 53.

Tell us...**Radiator leaking**

- Where is leak coming from? (See diagram opposite)

Fumes appear in room

- What is causing fumes?
- Has flue been cleaned recently?
- If the heating system is the cause, can you see manufacturer's name and the model?

Storage heater defective

- How many heaters are affected?
- Where are they?
- What appears to be the problem?
- Can you see manufacturer's name and model number?

Radiant/convector heater faulty

- What appears to be the problem?
- Can you see manufacturer's name and model?

TYPES OF INTERNAL DOOR

Fully glazed

Panelled

Top glazed

Flush

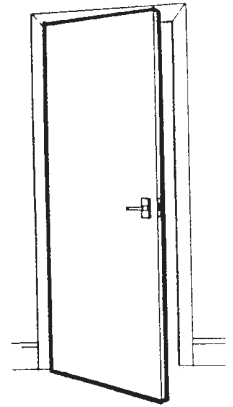
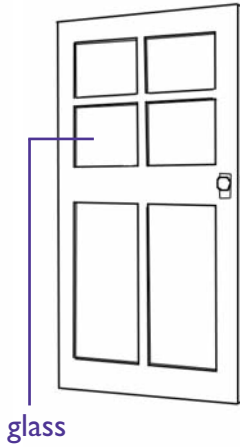
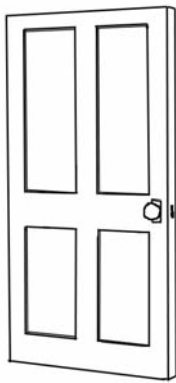
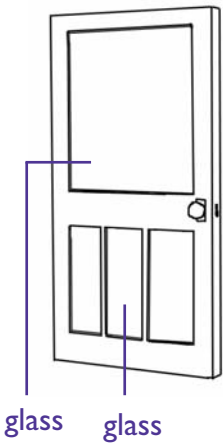

PERKO DOOR CLOSER

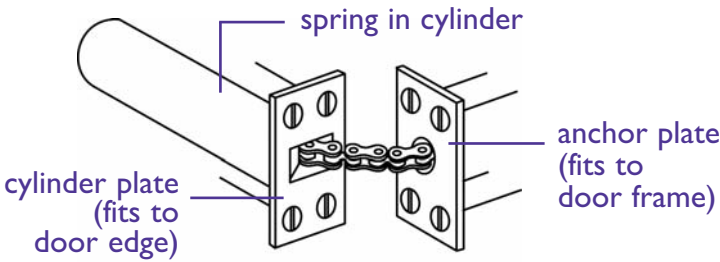

Louvred

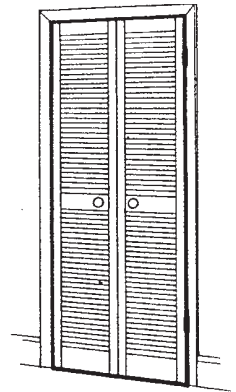

DOOR LATCH

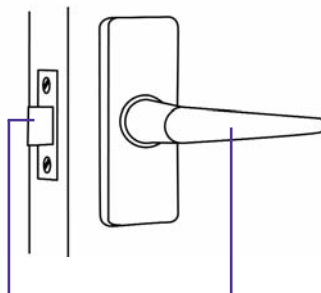

Before you contact us...**Tell us...****Door sticking/jamming**

- Where is door?
- What type of door is it?
(See diagrams opposite)
- What appears to be the problem?

Door damaged

- Where is door?
- What type of door is it?
(See diagrams opposite)
- What appears to be the problem?
- How did it happen?

Door latch defective

- What type of latch fitting is it?
- Where is door?
- What is wrong with it?
- How did it happen?

KITCHEN UNIT

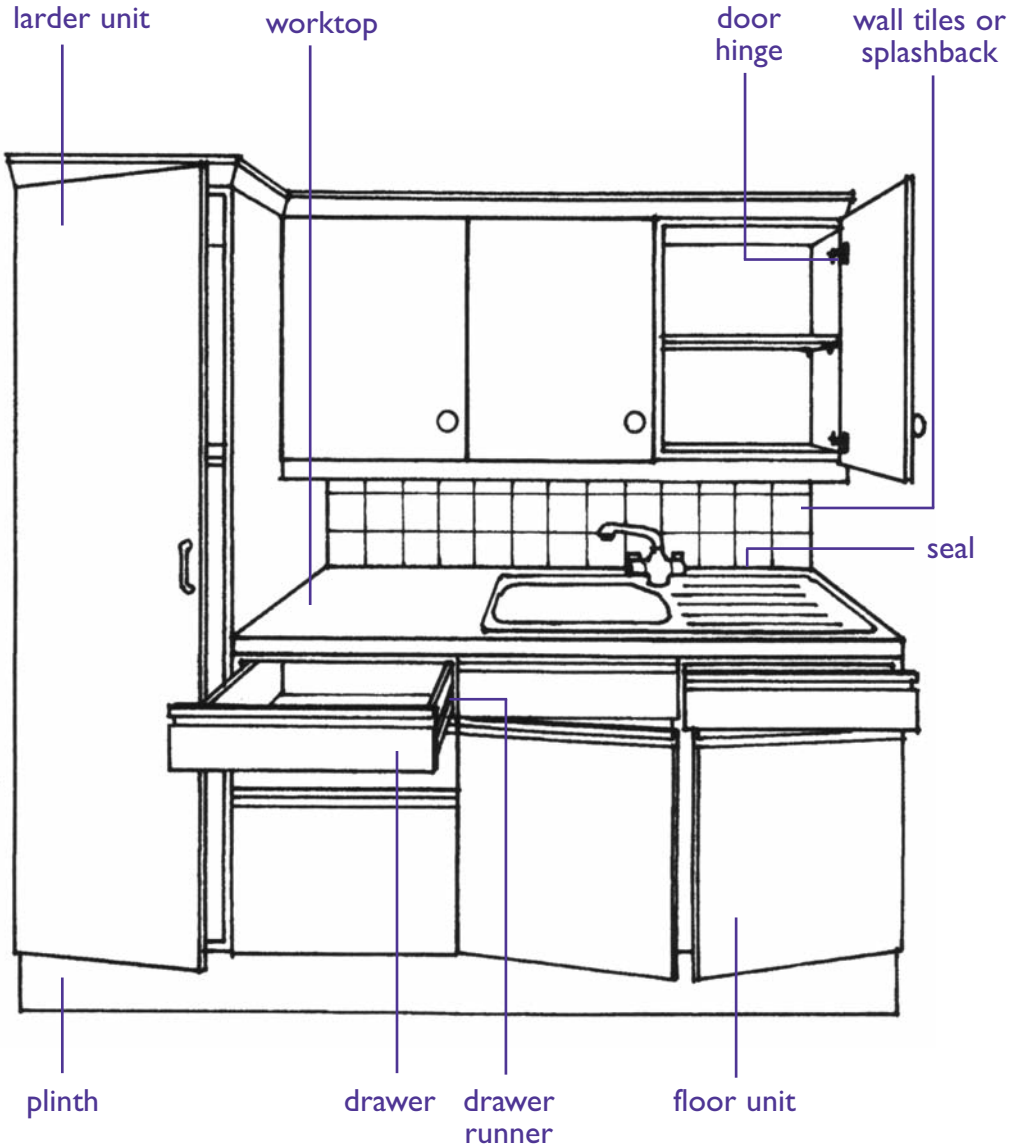

Before you contact us...

- Try to stop the leak causing more damage.
- Try to clear it yourself using a plunger. (See Helpful Tips, page 79)
- Stop others using sink while blocked.

Tell us...**Damaged cupboard**

- Which unit is affected?
(a corner unit, floor or wall unit, with single or double doors)
- What part is faulty?
(See diagram opposite)
- In what way is it damaged?
- Do you think it can be repaired or will it need to be replaced?
- What is it made of? (wood, plastic or metal etc)
- What colour and size is it?

Sink unit leaking

- Where is leak coming from?
(pipe, tap or waste pipe/trap. See diagram page 62)

Sink blocked

- Are other outlets affected?
- Is washing machine blocked?
- What caused the blockage?

Damaged wall tiles

- Where are tiles?
- Are they broken, loose or missing?
- How many are affected?
- What size and colour are they?

WASHING MACHINE

Showing typical plumbing

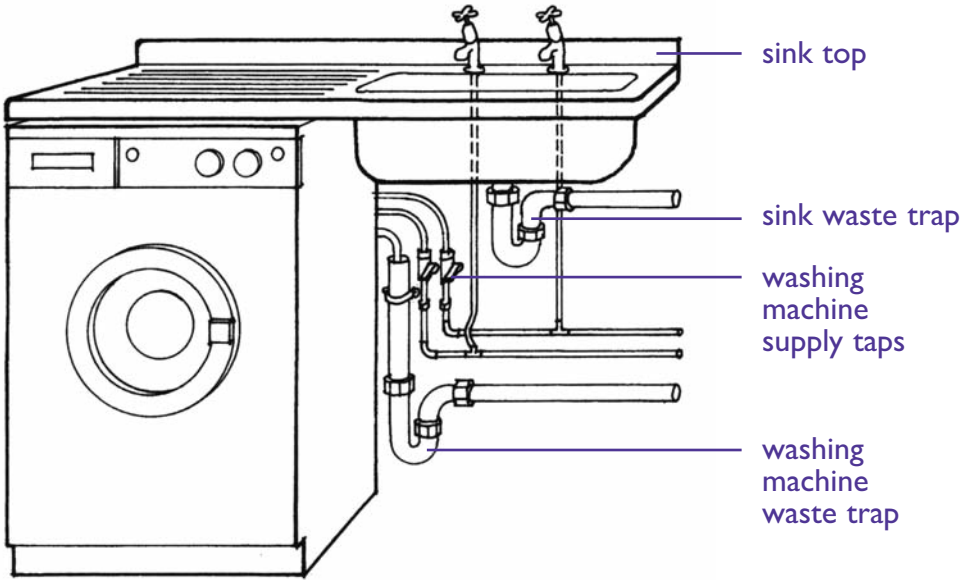

TYPES OF TAPS

Standard pillar tap



High neck pillar tap



Modern pillar tap



Mixer tap



Bib tap



Supatap

Before you contact us...**Tell us...****Seal gone around sink****Sink tap dripping**

- What type of tap is it?
(See diagrams opposite)

Tap loose

- What type of tap is it?
(see diagrams opposite)

Sink plug/chain required

- What happened to the plug
and chain?

Washing machine blocked

- Do you know what caused the
blockage?

Waste trap leaking

- What type of waste trap is it?
(See diagrams page 16)

CHIMNEY STACK

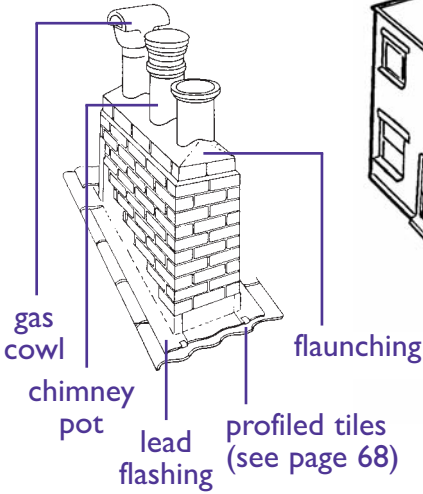

TYPES OF ROOFS

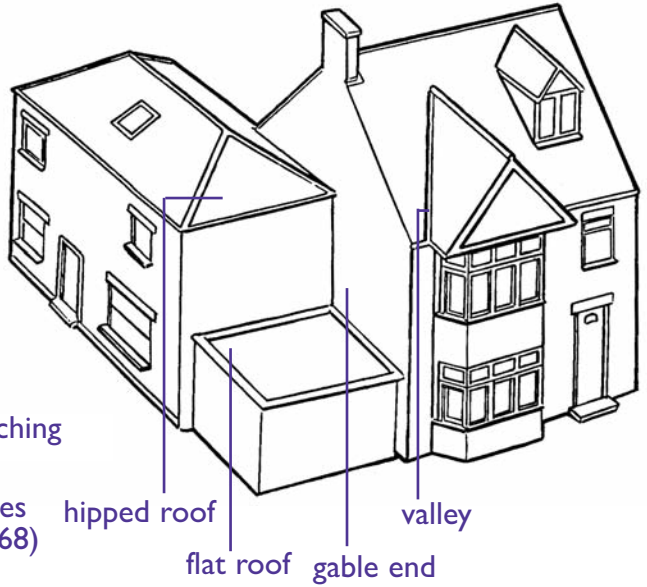

PITCHED ROOF

slate or plain tiles
(top surface flat)

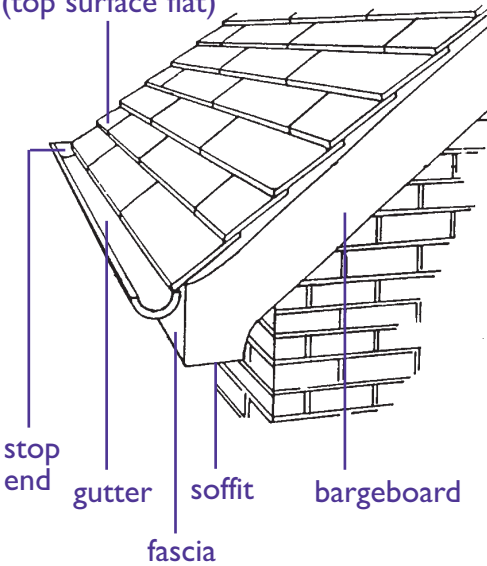

DORMER WINDOW

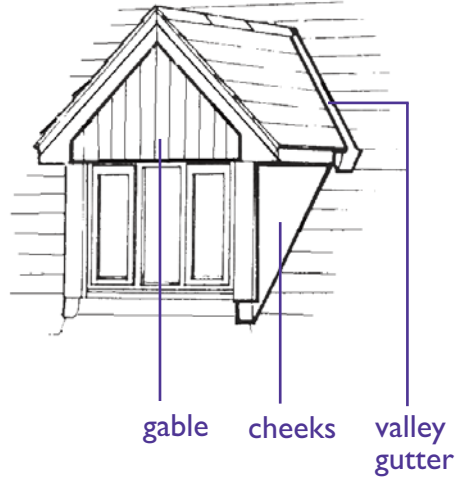

Before you contact us...

- If electrics are affected by water leakage, do not touch, and turn electricity off at consumer unit main switch.
 - If there is leakage, try to stop water causing more damage.
 - If it is dangerous, warn others.
-
- If electrics are affected by water leakage, do not touch, and turn electricity off at the consumer unit main switch.
 - If there is leakage, try to stop water causing more damage.
 - If it is dangerous, warn others.
-
- If it is dangerous, warn others.

Tell us...**Tiles/slates broken**

- What type of roof is it? (slate, tile etc)
- If roof is tiled, which type of tile? (flat or not flat. See page 68)
- Are they missing, broken or loose?
- Which part of the roof is affected? (See diagrams opposite)
- How large is area affected is?
- Is roof leaking?
- Are electrics affected?

Flat roof damaged

- What type of roof is it? (felt, asphalt or lead etc)
- Which part of roof is affected? (see diagrams opposite)
- How large is affected area?
- Is roof leaking?
- Are electrics affected?

Chimney stack damaged

- Which part is affected? (stack, pot or flashing etc See diagrams opposite)
- Is it damaged, loose or missing?
- Does chimney have more than one flue?
- Is it dangerous?

GUTTERS AND DOWNPIPES

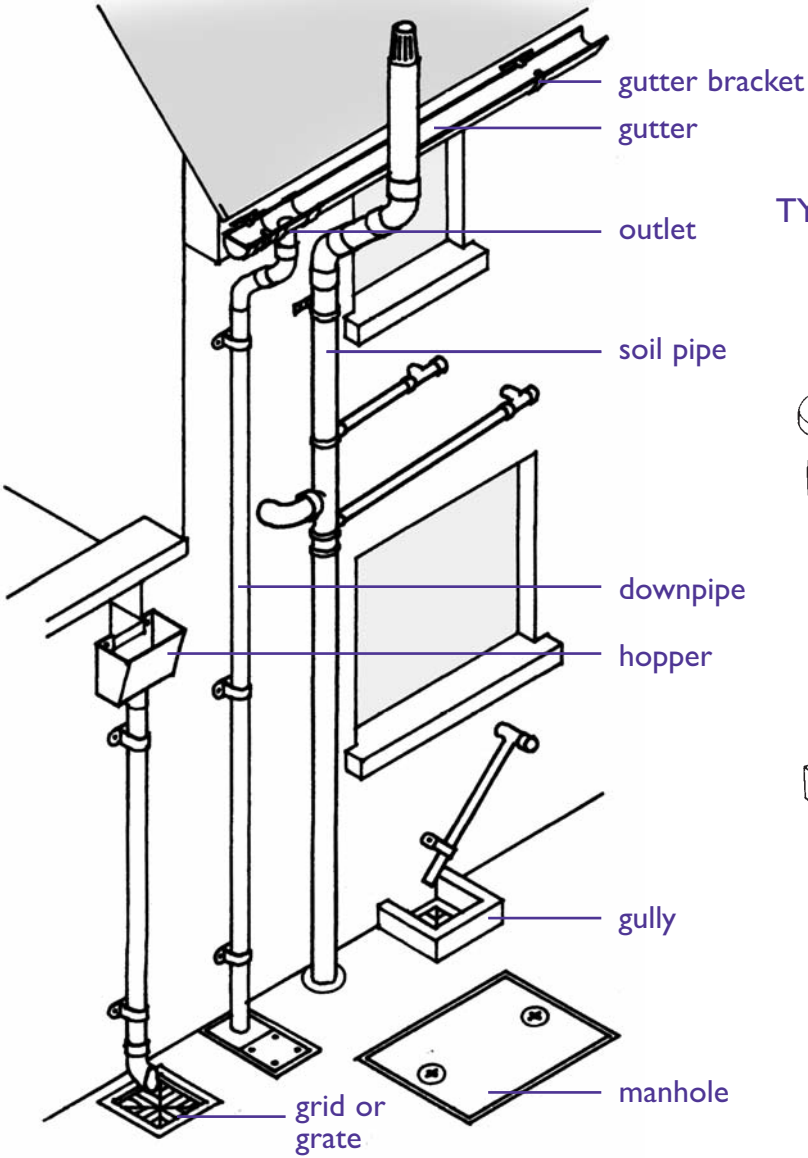

TYPES OF GULLY

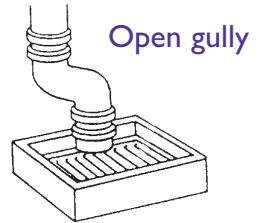
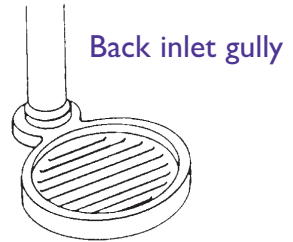

Before you contact us...

- If dangerous, put something over it to alert others to the danger.

Tell us...**Manhole cover defective**

- Where is it?
- What is the problem? (loose, broken or missing)
- What is it made of?
- Is it dangerous?

Manhole overflowing

- Where is it located?

Gully cover defective

- Where is it?
- What is the problem? (loose, broken or missing)
- Do you think it can be refixed or does it need to be replaced?
- What is it made of?
- What size is it?

Gutter overflowing

- Where is the overflow coming from? (gutter, hopper, pipe etc. See diagram opposite)

Gully blocked

- What is blocking the gully?

Drains blocked

- What is blocking the drain?

- Try to clear any leaves or other rubbish yourself with a stick.

TYPES OF TILES

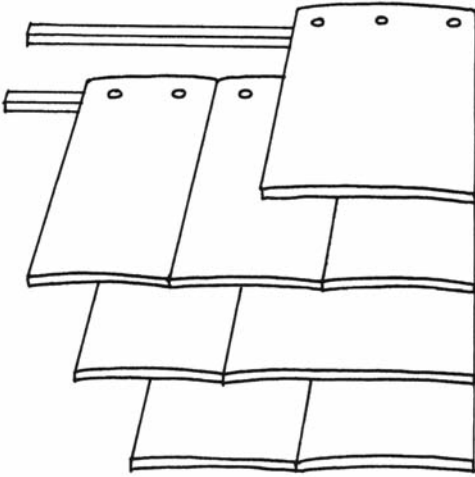

Plain tiles

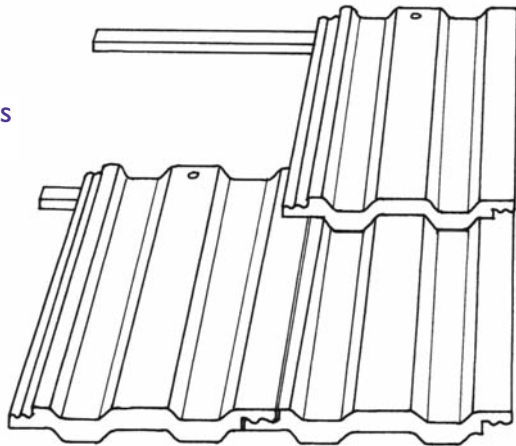

Profiled tiles

Before you contact us...**Tell us...****Guttering/downpipe defective**

- What is affected? (gutter or downpipe. See diagrams page 66)
- What is the problem? (guttering or downpipe is blocked, cracked, loose etc)
- If it is leaking, can you tell where from? (joint, or pipe etc. See diagram page 66)
- What is it made of? (metal, plastic etc)
- Can it be refixed or does it need to be replaced?

STAIRS

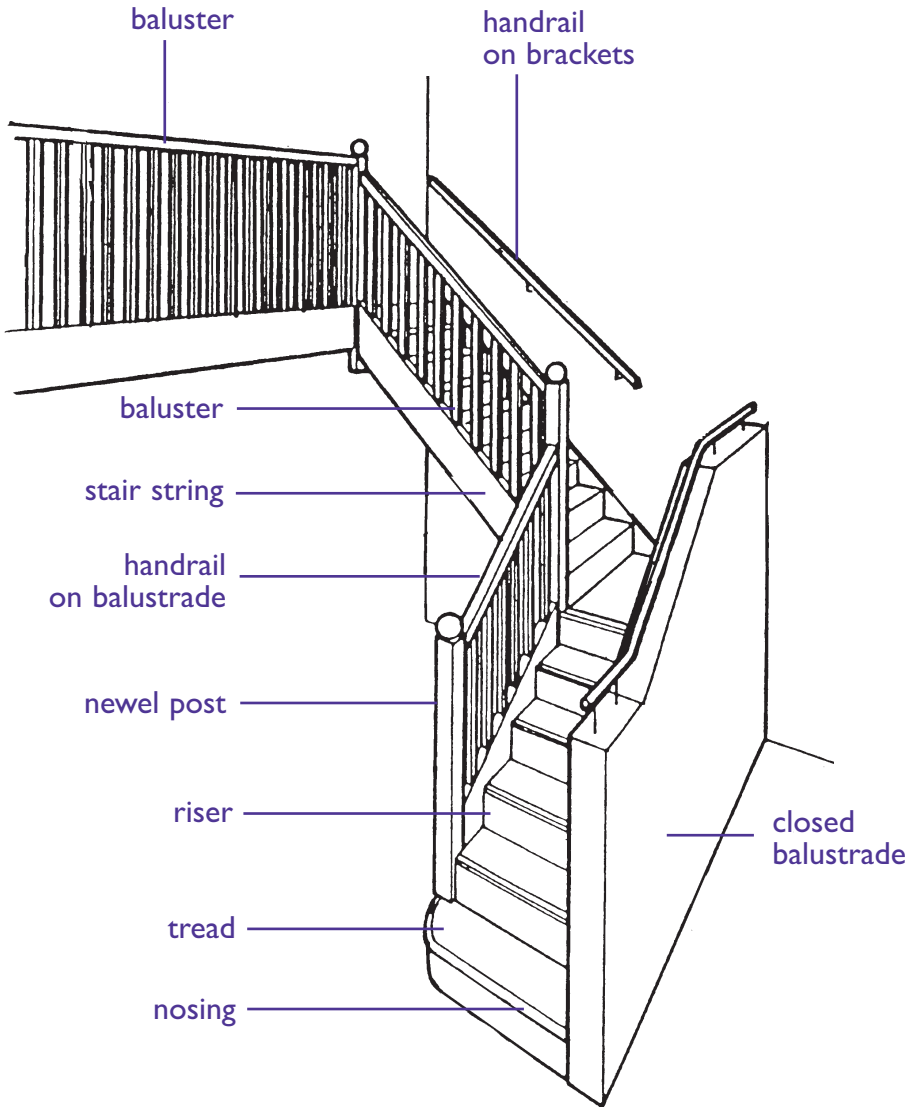

Before you contact us...

- If hazardous, warn others.

- If hazardous, warn others.

Tell us...**Loose tread**

- Is it inside your home or a communal staircase?
- What is the rough size of affected area?
- What are stairs made of? (wood, concrete etc)

Loose floorboard

- Is it inside your home or a communal area?
- What is the rough size of affected area?

Handrail or balustrade defective

- Is it inside your home or a communal area?
- Which part is affected? (handrail, post, individual baluster etc. See diagram opposite)
- Can it be refixed or does it need to be replaced?

Helpful tips

LOOKING AFTER YOUR HOME

You are responsible for keeping the inside of your home in good condition. To help you do this it is best to carry out small tasks and checks to prevent future problems such as:

- Wipe down on a regular basis all windows affected by condensation and if any mould has formed clean it off using a wash of diluted bleach, or a proprietary product available from all DIY stores. See Condensation below.
- Limescale can be removed from baths, sinks, shower heads, and taps with a descaler available from all DIY stores.
- Blockages in kitchen sink waste pipes can be prevented by flushing through using washing soda and hot water.
- Outside gullies should be kept

clear of leaves and other debris so that water drains away easily.

- Make sure you know where the main Stopcock is, and how to turn it off. Also, be sure to know how to turn off your electricity and gas supply in an emergency. If you do not, ask any of our staff or contractors when they next visit you.

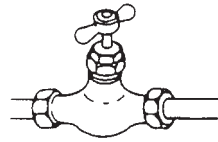

Stopcock or stop tap

In the Autumn you should check the following list of items and notify us of any problems. We can then repair them before they get worse and cause you any inconvenience:

- If you use an open fire have you swept the chimney? This is normally your responsibility.
- Are all your heating controls set correctly?

- Are there any tiles or slates missing or broken on your roof?
- Are there any leaks from gutters and downpipes?

CONDENSATION

Condensation occurs when there is an excessive build up of moisture in the air. There is always moisture in the air, but people create additional moisture in their homes by:

- Cooking, or boiling water.
- Taking baths or showers.
- Using paraffin or bottled gas heaters.
- Drying clothes indoors.

Warm moist air condenses and forms water when it cools: for example when it touches a cool surface. In your home these are outside walls, mirrors, windows, wall tiles and even on clothes.

If this condensation cannot dry out it will cause mould to form on walls, in cupboards and on window sills, and mildew to form on clothes, especially leather goods.

There are four things you can do to stop condensation forming:

- Produce less moisture by covering pans and turning down the heat when boiling, switching off boiling kettles, and drying clothes outside, or in a well ventilated room, and not using paraffin or bottled gas heaters.
- Ventilation to let the moisture out, by opening a bathroom or kitchen window for a while to let the steam escape, or using an extractor fan; and by opening windows for a while each day to change the air in your house.
- Keeping your home warm by at least keeping a low background heat: this need not result in significantly increased heating costs.
- Wipe down where moisture settles.

LEAKING, BURST OR FROZEN PIPES

When pipes leak

Place a dish or bowl underneath the leak. Pull back any carpets and

lay down newspapers or towels to absorb any dampness.

When pipes burst

Turn off the water at the main stop tap, and any gate valves from the water tank, and switch off any water heaters. Open all taps to drain water from the system.

Can it be isolated?

Some items of equipment may have their own isolation valve (either a gate valve, or a service valve).

Gate valve

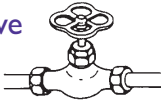

Service valve

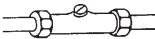

If not, you may be able to isolate the fault by just turning off a gate valve on a pipe coming out of the cold water tank. This will leave you with some services, even though it might only be cold water at the kitchen tap. You could then temporarily flush toilets using a bucket of cold water.

If electric fittings get wet

DO NOT TOUCH and turn off electricity at the meter.

When ceilings bulge

To prevent the ceiling falling down, place a bucket under the bulge and pierce a small hole to let the water through.

When pipes freeze

Turn off the water at the main stop tap and open the cold taps. It is best to leave the pipes frozen but you may try to thaw the pipe using hot water bottles or a hair dryer.

Take great care and **DO NOT USE A BLOW LAMP**. Take care to thaw from one end of the frozen section and not from the middle. Conserve hot water until the pipes are thawed.

General information

Know where your main stop tap is and check that it turns easily and is able to shut off the water supply. It is usually where the water pipe enters the house or near the kitchen sink.

Get to know where the gate valves for the hot and cold water tanks are.

If you go away for a few days in winter, lower the setting on your central heating room thermostat but leave the heating on.

BLEEDING A RADIATOR

When to do it

If the top part of a radiator is cold, this is because air is trapped in the system. Bleeding the radiator releases this air and allows hot water to fill the whole system.

Do not bleed if

Do not bleed the radiators if you have a Combination Boiler: this type of boiler will have either a pressure gauge or a low pressure light on the front or underside of the boiler, and you will probably not have a hot water cylinder.

Before bleeding

If the whole radiator is cold, check that the radiator valve is open. If more than one radiator is cold, the whole heating system will need to be checked by a plumber.

Turn off the heating system before bleeding, otherwise the pump might draw more air into the system.

You will need a special radiator key, available from most DIY and hardware shops. You will also need a rag or cloth and a bucket or bowl.

How to bleed

The bleed valve is the small square nut at the top end of the radiator. Place the key over the valve and hold the cloth around it to catch any water. Gently turn the key anti-clockwise until you hear a hiss - this is the air being released.

When water starts to come through, turn the key back clockwise to shut the valve off. **DO NOT** unscrew the valve completely as the plug will come right out.

Bleeding a radiator

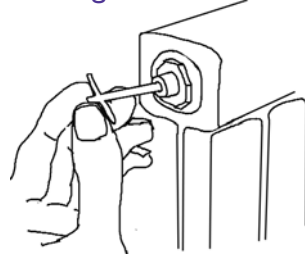

Thermostatic radiator valve

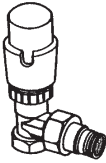

LOSS OF ELECTRIC LIGHT OR POWER

Fuse or trip switch

Check your consumer unit or fuse box: it will either have fuses or trip switches (see diagrams). Modern electric circuits are fitted with a circuit breaker fuse system: if a fault develops, a switch is tripped and the circuit is broken. Older ones have fuse holders and when the fuse is blown it must either be replaced, or rewired using special fuse wire of the correct amperage.

Electricity consumer unit

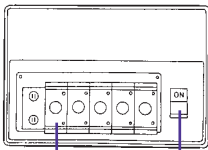

fuses or
circuit breakers

main on/off switch

Only replace a fuse if you are

confident you can do it safely, and have a replacement of the same amperage. If in doubt contact us or a qualified electrician.

Types of fuses

Trip switch

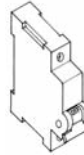

MCB



Cartridge type

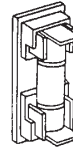

Rewirable type

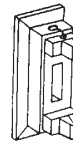

Trip switch
(replaces fuses
in modern
consumer units)

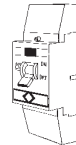

Setting a trip switch

Open the cover on the consumer unit to expose the trip switches. The Consumer Unit is usually next to the electricity meter. Check which switches have tripped to the OFF position and put them back to the ON position.

For more detail, refer to any handbook supplied.

If tripping occurs again

It is probably being caused by a faulty appliance. You need to identify which circuit is affected and which appliance on that circuit is causing a problem.

Which appliance is faulty?

Go around the house noting which set of lights or sockets are not working. Unplug all appliances on that problem circuit and switch off the immersion heater. Switch the tripped switch to the ON position and plug in the appliances one by one until the trip goes again. Leave that appliance unplugged.

If one of our appliances is at fault, report the repair; otherwise get it fixed yourself by a qualified electrician or service engineer.

What causes it to trip or blow a fuse?

- An overloaded circuit.
- Too many appliances being used at the same time.
- A faulty or misused appliance.
- Overfilled kettles.
- Unclean toasters.

- Cooker rings worn out or cracked.
- Faulty immersion heaters.
- Faulty connections on leads to appliances, eg hi-fi, TV, etc.
- Light bulbs blowing.

Plugs

The socket outlets in your home will take square pin plugs. The plug which you require will have a fuse inside it. We do not supply plugs and you will have to obtain them yourself.

To find out the correct type of fuse to fit in a plug, check the rating plate on the appliance.

Do not overload plug sockets by using multiple plug adaptors.

Warning

- Never tamper with the electricity company's fuse and seals.
- Never take any action unless you are confident you can do it safely.

CONTROLLING YOUR CENTRAL HEATING

How to set a digital timer

Check the clock is showing the correct time. If not, put the timer switch to 'clock' and adjust the time using the 'forward' and 'reverse' buttons. Reset the timer switch to 'auto'. Set the 'heating' and 'hot water' switches to come on once, twice, or stay on all the time, as you require. During freezing spells, keep the heating on all the time, and turn the thermostat down during the night and if you are out all day.

How to set a clock timer

Turn the clock until it is showing the correct time. Decide when you want the heating to come on and go off and set the pins or arrows for those times (see below for how to change pins and arrows). Set the timer switch to 'timer' or 'auto' as appropriate to the unit. During freezing spells, keep the heating on all the time, and turn the thermostat down during the night and if you are out all day.

How to control the temperature

To set the thermostat turn the dial so that the arrow or marker is against the temperature setting you want. A comfortable temperature is between 18°C and 22°C.

Changing pins on timeclock

Push them in against any time you want the heating to come on. Pull them out against any time when you want the heating to go off.

Changing arrows on timeclock

Slide the 'on' arrows (usually red) around the clock to the times when you want the heating to come on. Slide the 'off' arrows (usually blue) around to the times when you want the heating to go off.

Digital programmer

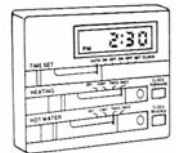

Clock programmer

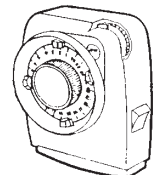

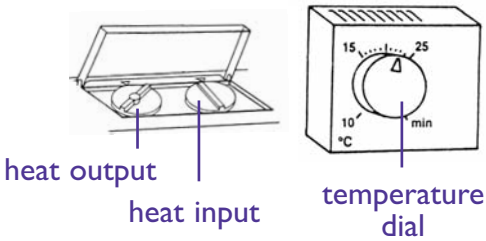

CLEARING A BLOCKED WASTE PIPE

Clearing a sink or bath blockage

Bale out most of the water using a suitable container. Hold a rag firmly over the overflow opening, and place a plunger over the drain hole. Pump the plunger up and down rapidly. Plungers can be obtained from most DIY shops.

After clearing the blockage, it is advisable to clean out the trap.

Clearing a blocked waste pipe

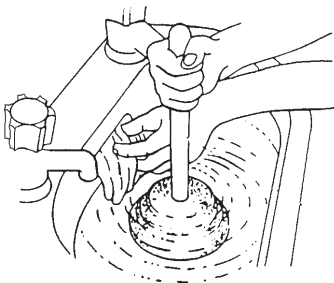

Cleaning out a waste trap

First bale out any excess water from the bath, basin, or sink using a jug or bowl. Place a bowl underneath the trap and unscrew the joints to remove the trap.

Clean thoroughly and replace the trap, checking that the seals are in place and that all joints are screwed up tightly.

If more than one fitting is blocked

The problem may be in the soil stack or main drain. This will need to be cleared by one of our contractors. Blockages are usually caused by the build-up of fat, tea leaves, hair, etc. It is advisable to clean wastes with hot water and soda crystals.

CLEARING A BLOCKED WC

Clearing blockages

If the pan is already full, remove some of the water into a suitable container using a jug or bowl. Push the toilet brush or plunger to the bottom of the pan and pump up and down vigorously about 10

times. This creates a vacuum and pressure which may shift the blockage. Check by flushing the toilet to see whether the blockage has gone. You may need to repeat the process several times before the toilet flushes normally. Do not use plungers with a metal disk, as these may chip or crack the toilet bowl.

Clearing a blocked WC

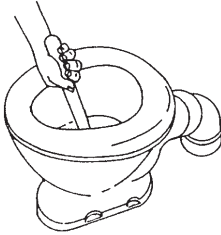

Avoiding blockages

Air fresheners that attach to the rim of the toilet pan should be fastened securely to ensure they do not fall in and cause a blockage. Blockages are usually caused by unusual objects: nappies, toys, sanitary towels, air fresheners, etc. If such a blockage occurs as a result of one or several of these objects becoming lodged, you may be charged for clearing the blockage.

OVERFLOWS

To stop an overflow

If the toilet cistern is overflowing try lifting the float to close the ball valve: if this stops the overflow, try to tie it up, using a piece of wood and some string, as in the diagram.

Typical toilet cistern

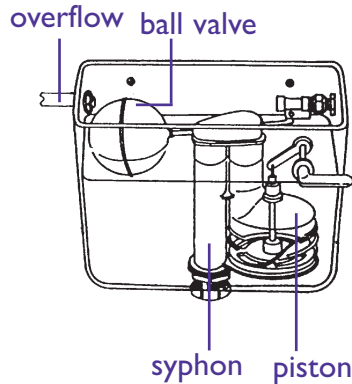

Cistern showing float tied up

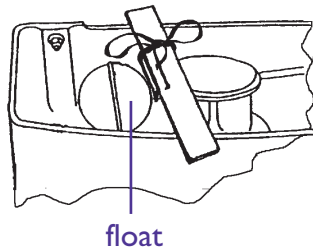

You can do the same with a cold water storage tank as a temporary measure.

Cold water storage tank

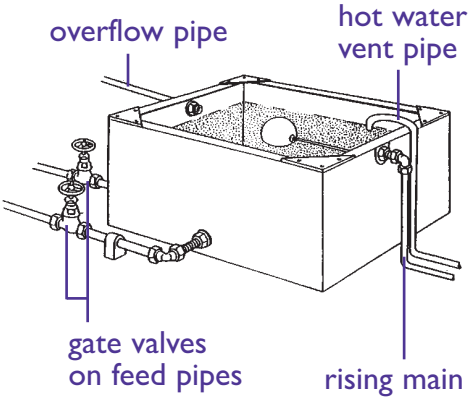

STOPCOCKS, GATE VALVES ETC

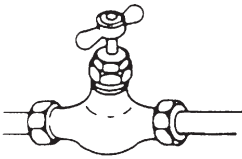

Stopcock or stop tap

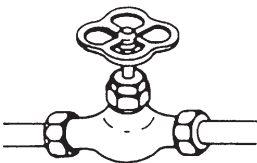

Gate valve

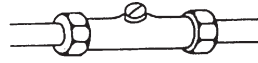

Service valve

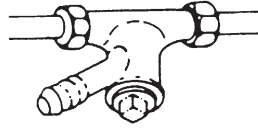

Draincock

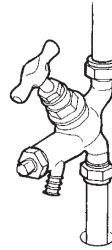

Stopcock with drain valve

Index

Basin

| | |
|-----------------------|----|
| Blocked | 17 |
| Damaged / broken | 17 |
| Tiles damaged | 19 |
| Plug chain required | 19 |
| Seal gone | 19 |
| Tap dripping / faulty | 19 |
| Tap loose | 19 |
| Water leaking | 17 |

Bath

| | |
|-----------------------|----|
| Blocked | 17 |
| Damaged / broken | 17 |
| Tiles damaged | 19 |
| Plug chain required | 19 |
| Panel loose | 19 |
| Seal gone | 19 |
| Tap dripping / faulty | 19 |
| Tap loose | 19 |
| Water leaking | 17 |

Boiler (central heating) faulty 55

Chimney damaged 65

Clothes line

| | |
|-----------------|----|
| Broken / stolen | 45 |
| Post broken | 45 |

Cupboard (kitchen) damaged 61

Door (internal)

| | |
|-------------------|----|
| Damaged | 59 |
| Sticking / jammed | 59 |
| Latch damaged | 59 |

Door (external)

| | |
|--|----|
| Draught | 35 |
| Frame damaged / rotten | 33 |
| Glass damaged / broken | 35 |
| Ironmongery (letterplate, handle etc) | 37 |
| Jammed | 33 |
| Lock not working | 37 |
| Rain coming in | 35 |
| Threshold damaged | 33 |
| Weatherboard damaged | 35 |

Door entry faulty 31

Downpipe / guttering faulty 69

Drains blocked 67

Electrics: none at all 51

Electrical appliance faulty 53

Electrical fitting smoking 51

EMERGENCIES 15

Extractor fan faulty 55

Fence dangerous / broken 43

Fumes in room 57

Garage door faulty 45

| | | | |
|------------------------------------|----|---------------------------------|----|
| Gate | | Locked out | 37 |
| Damaged | 47 | Manhole | |
| Jamming / sticking | 49 | Cover broken | 67 |
| Latch / bolt faulty | 49 | Overflowing | 67 |
| Post rotten / broken | 49 | Path damaged | 47 |
| Post stop damaged | 49 | Pipe | |
| Gully | | Banging | 27 |
| Blocked | 67 | Burst | 27 |
| Cover defective | 67 | Plug socket failed | 53 |
| Guttering / downpipe faulty | 69 | Power: none at all | 51 |
| Gutter overflowing | 67 | Radiator | |
| Heating | | Leaking | 57 |
| Communal | 55 | Not heating up | 55 |
| Radiant / convector | 57 | Roof damaged | 65 |
| Storage | 57 | Rubbish chute faulty | 31 |
| Helpful tips | 72 | Rubbish dumped in garden | 45 |
| Hot water stopped | 29 | Sealing strip gone | |
| Keys lost | 37 | Around basin | 19 |
| Leak | | Around shower | 21 |
| From bath / basin | 17 | Around kitchen sink | 63 |
| From kitchen sink | 61 | Shower | |
| From radiator | 57 | Blocked | 21 |
| From WC | 23 | Cubicle door faulty | 23 |
| Lighting | | Curtain damaged | 21 |
| Failed | 51 | Hose broken | 21 |
| Fluorescent tube gone | 51 | Not working | 21 |
| (Emergency) faulty | 31 | Seal gone around tray | 21 |
| (Communal) faulty | 31 | | |

| | | | |
|---------------------------------------|----|--------------------------------------|----|
| Shower arm broken | 21 | Tiles (wall) damaged | |
| Switch broken | 21 | Bath / basin | 19 |
| Tray broken | 21 | Kitchen sink | 61 |
| Tiles damaged | 23 | Shower | 23 |
| Sink (kitchen) | | TV aerial (communal) faulty | 31 |
| Blocked | 61 | Wall (garden) dangerous or collapsed | 49 |
| Tap dripping | 63 | Washing machine blocked | 63 |
| Tap loose | 63 | Waste blocked (bath / basin) | 17 |
| Unit leaking | 61 | Water | |
| Slates damaged | 65 | Hammer/banging pipes | 37 |
| Smoke detector faulty | 53 | Leaking | 37 |
| Soil stack blocked | 25 | Leaking from bath / basin | 17 |
| Splashback damaged | | No cold water | 37 |
| Around bath / basin | 19 | Tank overflow running | 37 |
| Around kitchen sink | 61 | WC | |
| Around shower | 23 | Blocked | 25 |
| Stairs | | Leaking | 23 |
| Handrail / balustrade | | Flush not working | 23 |
| or spindle loose | 71 | Overflow running | 25 |
| Floorboard loose | 71 | Seat damaged | 25 |
| Tread loose | 71 | Soil stack blocked | 25 |
| Tank (storage) overflowing | 27 | Window | |
| Tap dripping / faulty on basin / bath | 19 | Frame jammed / sticking | 39 |
| Tap loose on bath / basin | 19 | Glass damaged / broken | 39 |
| Threshold damaged | 33 | Ironmongery | |
| | | (handle, fastener etc) | 41 |
| | | Weatherboard damaged | 35 |

Notes

Notes

Notes

Equality and Diversity

Longhurst Homes is committed to equality and recognises diversity in all areas of our work. We seek to treat people with respect and deliver services that meet individual need.

This document is also available in:



Large print



Audio



Braille



Other languages

Please contact Longhurst Homes Limited on freephone 0800 111 4013 if you want this information in another format.

Если вы хотели бы получить этот документ на другом языке или в другом формате, или если вам необходимо воспользоваться услугами переводчика, просим обращаться в администрацию.

যদি আপনি এই ডকুমেন্ট অন্য ভাষায় বা ফরমেটে চান অথবা যদি আপনার একজন ইন্টারপ্রেটারের প্রয়োজন হয়, তাহলে দয়া করে আমাদের সাথে যোগাযোগ করুন।

اگر این مدرک را به زبانی دیگر یا در فرمتهی دیگر میخواهید و یا اگر احتیاج به سرویس مترجم دارید، لطفاً با ما تماس بگیرید

Si vous souhaitez obtenir ce document dans une autre langue ou sous un autre format ou si vous avez besoin des services d'un interprète, veuillez nous contacter.

نه گهر دهتهوی نه بهلگهیهت به زمانیکی که یا به فورمیکی که ههیی، یا پیویستت به موته رجیم ههیه، تکایه په یوه نهدیمان پیوه بکه

Jeżeli chcieliby Państwo otrzymać ten dokument w innym języku lub w innym formacie albo jeżeli potrzebna jest pomoc tłumacza, to prosimy o kontakt z nami.

Se gostaria de ter este documento noutro idioma ou formato, ou se necessita de um intérprete, contacte-nos.

ਜੇ ਇਹ ਦਸਤਾਵੇਜ਼ ਤੁਹਾਨੂੰ ਕਿਸੇ ਹੋਰ ਭਾਸ਼ਾ ਵਿਚ ਜਾਂ ਕਿਸੇ ਹੋਰ ਰੂਪ ਵਿਚ ਚਾਹੀਦਾ ਹੈ, ਜਾਂ ਜੇ ਤੁਹਾਨੂੰ ਗੱਲਬਾਤ ਸਮਝਾਉਣ ਲਈ ਕਿਸੇ ਇੰਟਰਪ੍ਰੈਟਰ ਦੀ ਲੋੜ ਹੈ, ਤਾਂ ਤੁਸੀਂ ਸਾਨੂੰ ਦੱਸੋ।

یہ دستاویز اگر آپ کو کسی دیگر زبان یا دیگر شکل میں درکار ہو، یا اگر آپ کو ترجمان کی خدمات چاہیں تو براے مہربانی ہم سے رابطہ کیجئے۔



REPAIR GUIDES

4th Edition ISBN: 0 86297 344 9

Copyright jointly held by Housing Software and Rand Associates

Published by Housing Software www.m3h.co.uk

Thanks to the NHMF for drawings, advice and testing the product